

Aria
Child^{INC.}



Volkswagen Beetle

Owner's Manual and Assembly Instructions

Model W486TG

Read and understand the entire manual before assembly and operation. The vehicle must be assembled by an adult who has read and understands the instructions.

Made in China.

Styles and colors may vary. Do not return to store. Call 1-888-982-9309 for assistance and replacement parts.

Save this manual with your sales receipt.



The 21st Century Beetle is officially licensed by Volkswagen. Manufactured and distributed by or for Paragon Child Products Co., Ltd. (Goodbaby Group). Trademark "VW-in-circle logo", associated design patents and copyrights are used with the approval of the owner Volkswagen AG.

Introduction

Thank you for purchasing this vehicle from Aria Child. We hope the rider enjoys it for miles to come. Please read this instruction guide carefully before assembling and operating the vehicle.

Please contact Aria Child Customer Service with any questions.

Hours: 9 AM - 5 PM (CST), Monday - Friday

Phone: 1-888-982-9309

Email: customerservice@ariachild.com

Web: www.ariachild.com

Specifications:

BATTERY	6V 7AH
MOTOR	6V 15W
AGE	3 Years and Up
MAX WEIGHT	77 lbs. (35 kg)
PRODUCT SIZE	41.34 x 23.23 x 20.87 in. (1050x590x530 mm)
SPEED	2.5MPH
RECHARGE TIME	8-12 Hours
TYPICAL RUN TIME	1-2 Hours
CHARGER OUTPUT	DC 7.0V0.7A

IMPORTANT!

**YOU MUST CHARGE THE BATTERY
FOR 24 HOURS BEFORE FIRST USE!**

Charge the battery after each use.

Charge the battery at least once a month, even if the vehicle is not in use.

**DO NOT RETURN THIS ITEM
TO THE STORE!**

Call Customer Service if you need assistance or replacement parts.

1-888-982-9309

**Read this entire manual to ensure
proper assembly and safe operation
of the vehicle.**



Table of Contents 5

Safety	6
Parts	8
Charging Instructions	9
Assemble the Front Wheels	10
Assemble the Left Rear Wheel	11
Assemble the Right Rear Wheel	12
Attach the Windshield and Spoiler	13
Attach the Steering Wheel	14
Attach the Mirrors	15
Attach the Seat	16
Battery Removal	17
Operating Instructions	18
Maintenance	19
General Care	20
Troubleshooting Guide	21
FCC Information	23
Service and Repairs	24
Warranty	25
Product Registration	27



WARNING: SAFETY RIDING RULES

The user must follow all safety rules and guidelines, or serious injury or death may occur to the user.

- Always use common sense and safe practices when using the vehicle. The user must be at least 3 years old and weigh no more than 77 lbs.
- This product contains small parts that are for adult assembly only. Keep small children away when assembling. Remove and dispose of all protective material and plastic bags before assembly.
- Riders must always wear a fitted helmet that complies with U.S. Consumer Product Safety Commission (CPSC) Standard CFR 1203.
- Only sit on the seat in the vehicle.
- Do not allow more than one rider.
- Do not overload the vehicle. Do not remove the weight restriction decals.
- Do not pull the vehicle with another vehicle or similar device.
- Keep body parts such as hands, legs, hair and clothing away from moving parts. Moving parts can cause serious injury.
- Always wear shoes in the vehicle.
- Do not operate near streets or motor vehicles.
- Do not operate near drop-offs such as steps, steep inclines or hills. Operate on relatively level ground.
- Do not operate near water, swimming pools or other fluids.
- Do not operate in dangerous weather conditions such as rain or snow.
- Do not operate near loose dirt, mud, sand or fine gravel.
- Do not operate near flammable vapors (gasoline, paint thinner, acetone, etc.).
- Always use the vehicle in a safe, secure environment with adult supervision.



WARNING: BATTERY SAFETY

- Battery posts, terminals and related accessories contain lead and lead compound (acid) chemicals known to the state of California to cause cancer, reproductive harm, and are toxic and corrosive. DO NOT open the battery.



- Contact exposure to battery leakage (lead acid) may cause serious injury. Immediately contact your doctor if exposure occurs. If the chemical is on the skin, flush immediately with cool water for 15 minutes. If the chemical is swallowed, immediately give the person water or milk. Do not give water or milk if the person is vomiting or has decreased alertness. Do not induce vomiting.

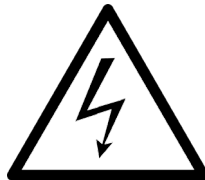

- Tampering with or modifying the electric circuit system may cause shock, fire or explosion. It could permanently damage the system. Keep the charger housing closed to prevent exposed wiring, which may cause electric shock.

IMPORTANT: Before using the vehicle for the first time, the battery must be charged for a full 24 hours (no more than 30 hours).



WARNING: ADULT SUPERVISION REQUIRED

- Before using the vehicle, the rider must understand the vehicle controls and safety issues.
- It is the responsibility of the adult to educate the child and to determine if the child is capable of understanding the vehicle controls.
- An adult must ALWAYS directly supervise the use of this vehicle.
- NEVER leave a child unsupervised in the vehicle.

8 Parts

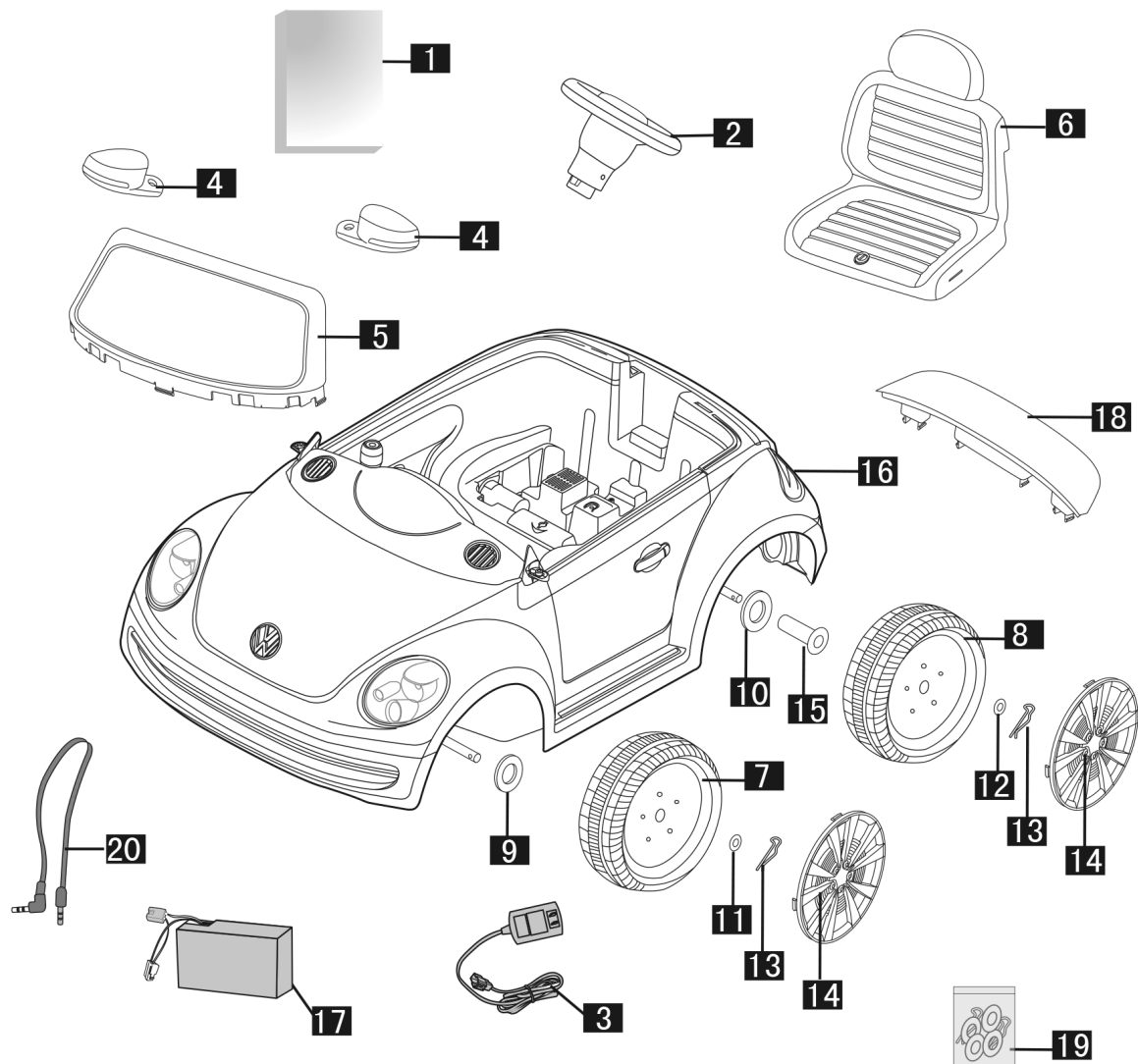

- | | |
|----------------------------|----------------------------|
| 1. Manual | 11. Front thin washer |
| 2. Steering wheel assembly | (10 x 1 mm) (2) |
| 3. Battery charger | 12. Rear thin washer |
| 4. Mirrors (2) | (12 x 1 mm) (2) |
| 5. Windshield | 13. Snap pins (4) |
| 6. Seat | 14. Rims (4) |
| 7. Front wheels (2) | 15. Rear wheel orientation |
| 8. Rear wheels (2) | sleeve |
| 9. Front thick washer | 16. Car body |
| (10 x 2 mm) (2) | 17. Battery |
| 10. Rear thick washer | 18. Rear spoiler |
| (12 x 2 mm) (1) | 19. Hardware bag |
| | 20. MP3 Cable |

Not Included:

- Phillips screwdriver
- Pliers

YOU MUST CHARGE THE BATTERY FOR 24 HOURS BEFORE THE FIRST USE!

ONLY AN ADULT SHOULD HANDLE THE BATTERY AND CHARGER.

To Charge the Battery:

1. Ensure the car is stopped and turned off.
2. Unlock and remove the seat.
3. Unplug the battery connector (A) from the engine connector (B).
4. Connect the battery connector (A) to the battery charger connector (C) and plug (D) into a 120 V outlet.

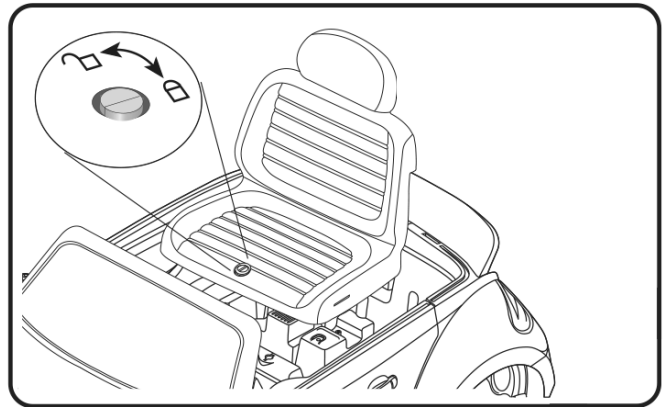

To Unplug the Battery:

1. Unplug the battery charger (D) from the outlet.
2. Unplug the battery connector (A).
3. Reconnect the battery connector (A) to the engine connector (B).
4. Replace the seat and tighten lock.

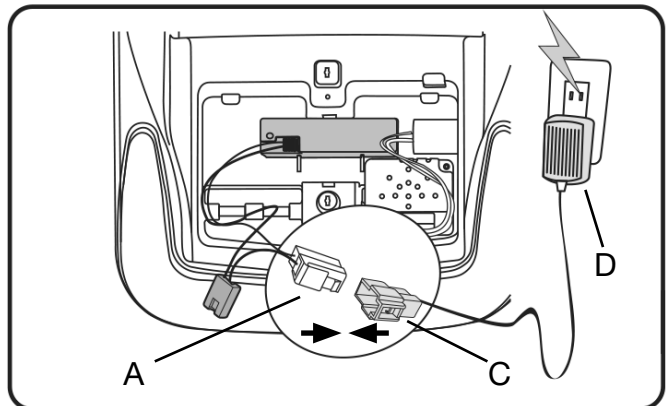
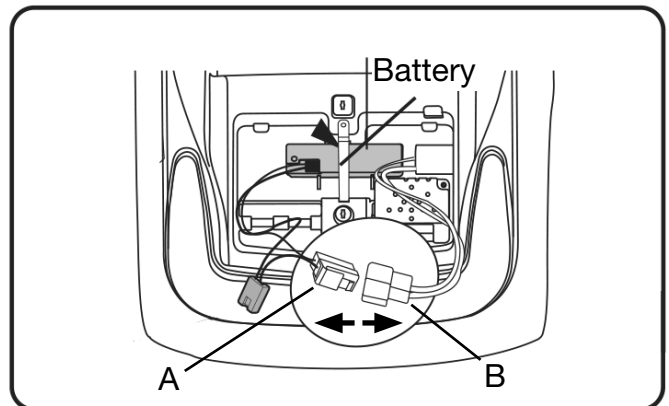

Note: It is not necessary to remove the battery for charging. However, if the battery does not reach the outlet, it can be removed for charging. For Battery Removal instructions, see Page 17.

10 Assemble the Front Wheels

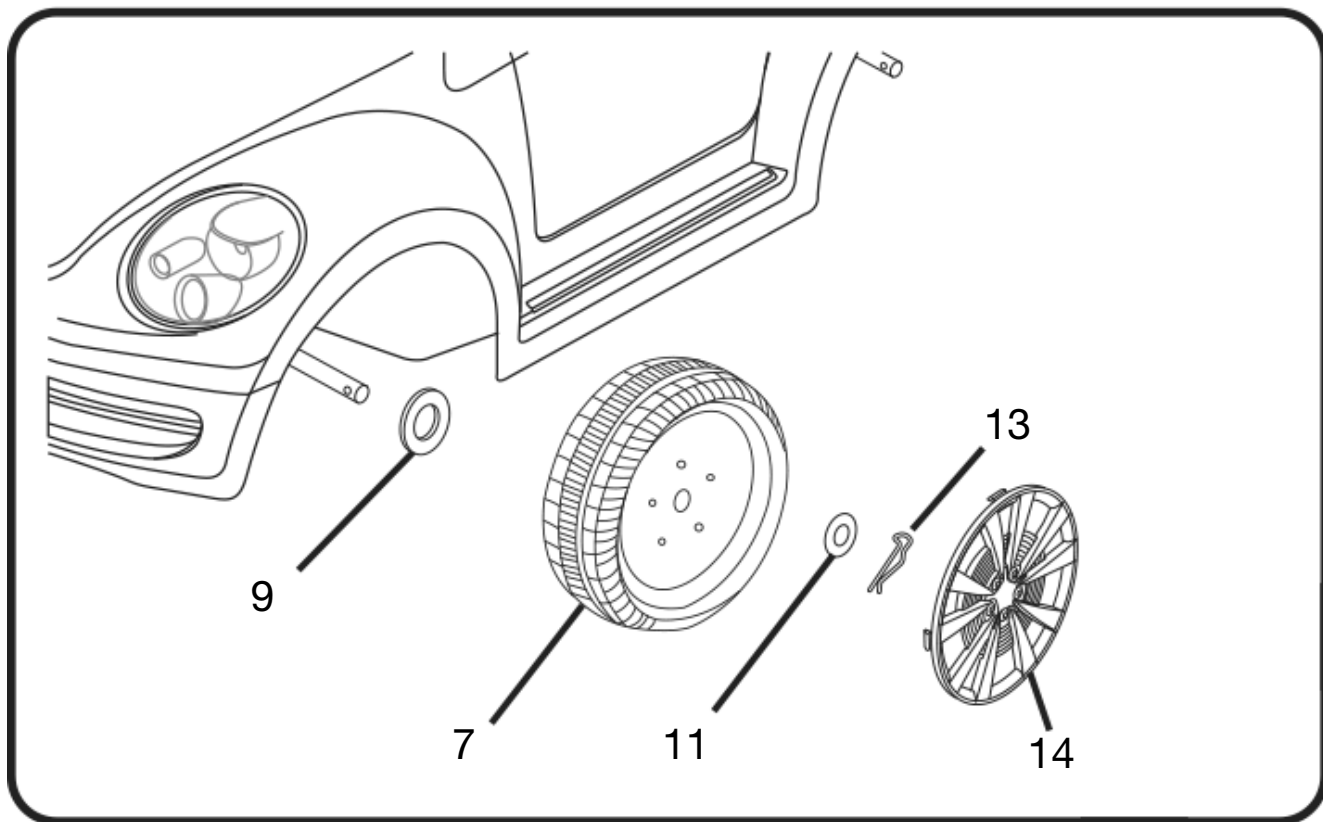

1. Slide the front thick washer (9) onto the front axle.
2. Slide the front wheel (7) onto the front axle.
3. Slide the front thin washer (11) onto the front axle.
4. Slide the snap pin (13) into the hole on the front axle until firmly attached.
5. Snap the rim (14) onto the completed wheel assembly.
6. Repeat steps 1-5 for the remaining front wheel.

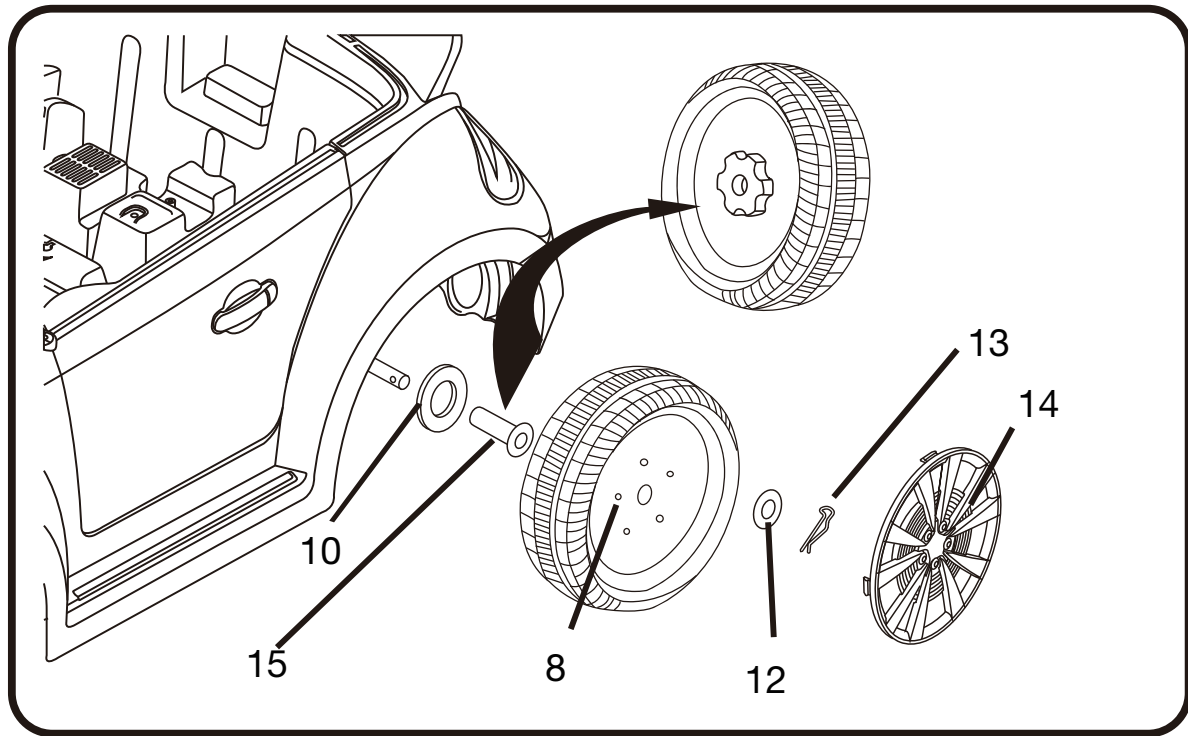

Left Rear Wheel:

1. Slide the rear thick washer (10) onto the left rear axle.
2. Slide the rear wheel orientation sleeve (15) onto the left rear wheel axle.
3. Slide the left rear wheel (8) onto the left rear axle. The side with the gear teeth faces inward.
4. Slide the rear thin washer (12) onto the left rear axle.
5. Slide the snap pin (13) into the hole on the left rear axle until firmly attached.
6. Snap the rim (14) onto the completed left wheel assembly.

12 Assemble the Right Rear Wheel

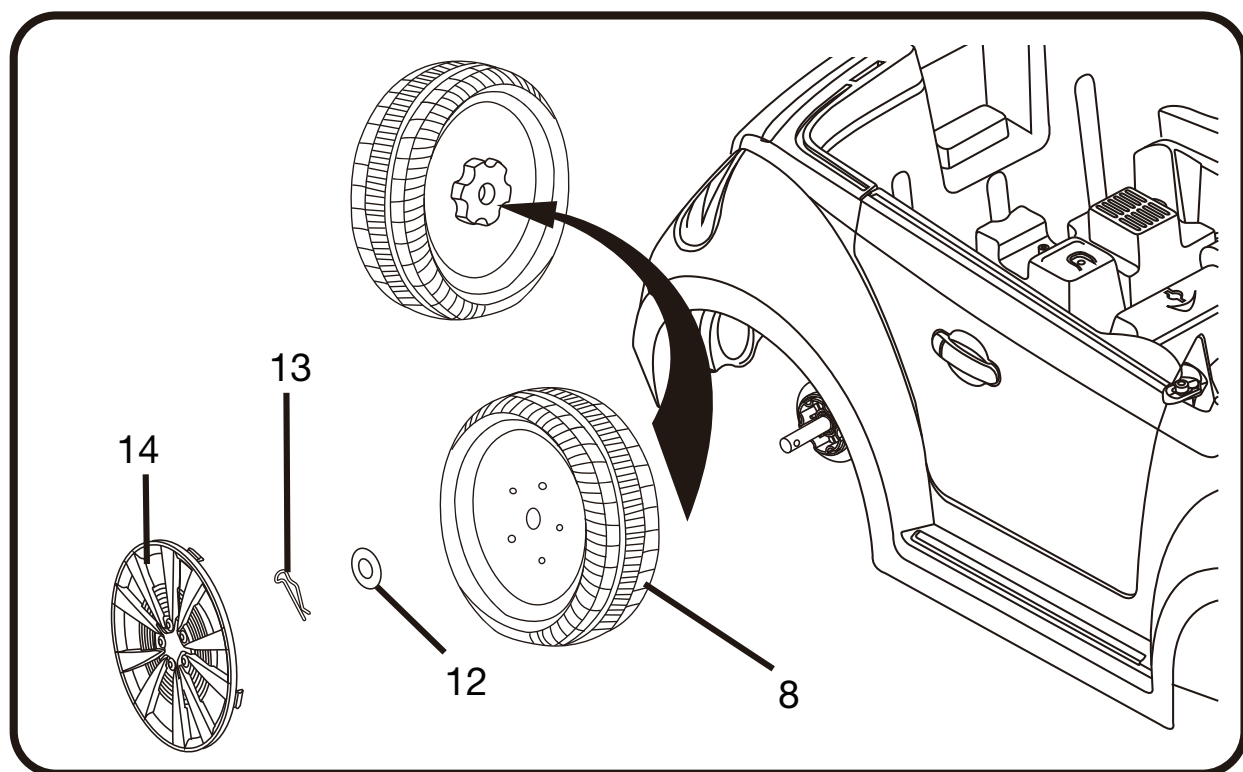

Right Rear Wheel:

1. Slide the right rear wheel (8) onto right rear wheel axle. The side with gear teeth faces inward. (Note: the gear teeth must engage with the gear box.)
2. Slide the rear thin washer (12) onto the right rear axle.
3. Slide the snap pin (13) into the hole on the right rear axle until firmly attached.
4. Snap the rim (14) onto the completed right wheel assembly.

Attach the Windshield and Spoiler 13

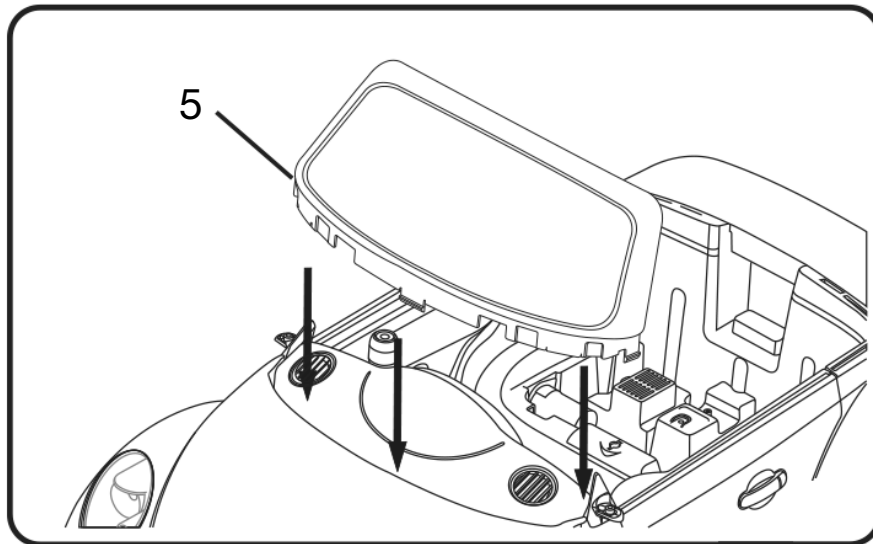

1. Align the windshield (5) with the two side slots between the dashboard and the body.
2. When evenly aligned, push lightly on the windshield while holding at each end until it clicks. (Note: the two sides of the windshield must be pushed in evenly.)
3. Push down lightly on the middle of the windshield until it clicks.

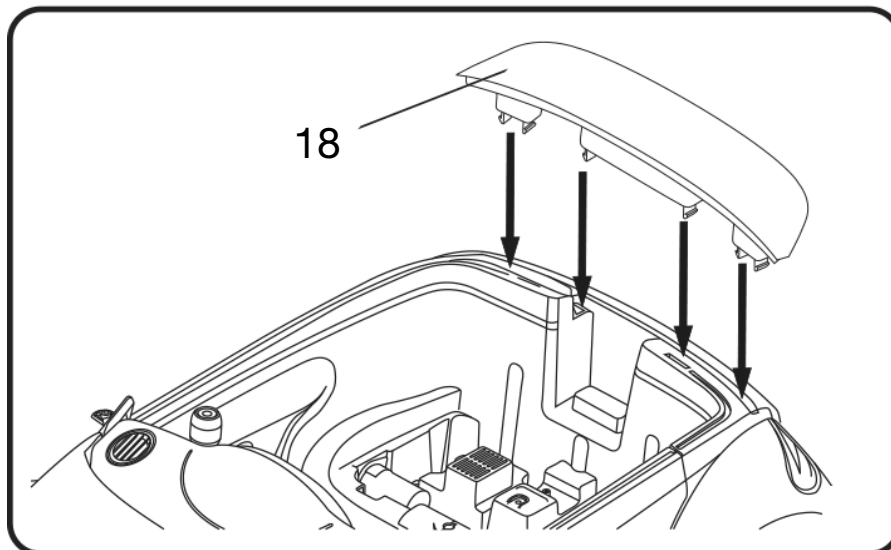

1. Align the snaps of the rear spoiler (18) with the corresponding slots on the rear body.
2. Push down lightly on the spoiler until it clicks.

14 Attach the Steering Wheel

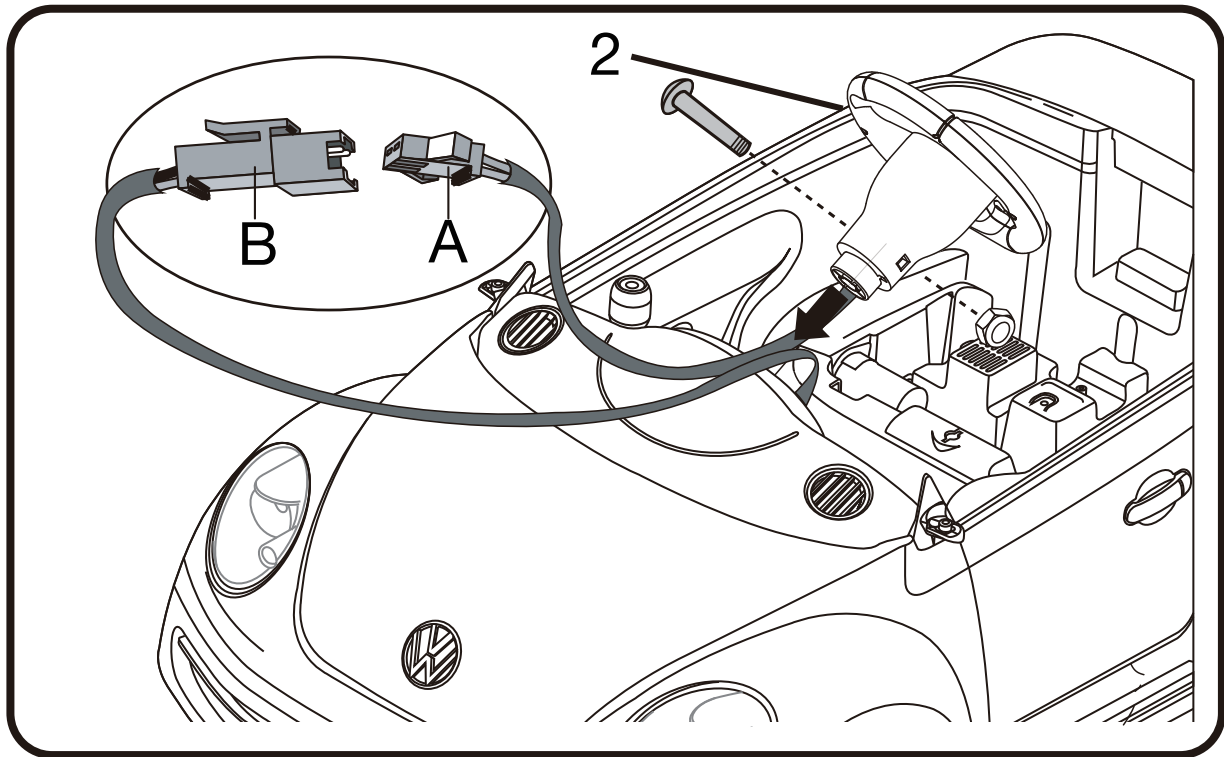

1. Remove the screw and nut from the steering wheel assembly before attaching.
2. Plug the steering wheel connector (A) into the dashboard connector (B).
3. Insert the steering wheel (2) into the steering rod, and match the screw holes of the steering wheel and the steering rod.
4. Insert the screw into the hole and fasten the nut to secure.

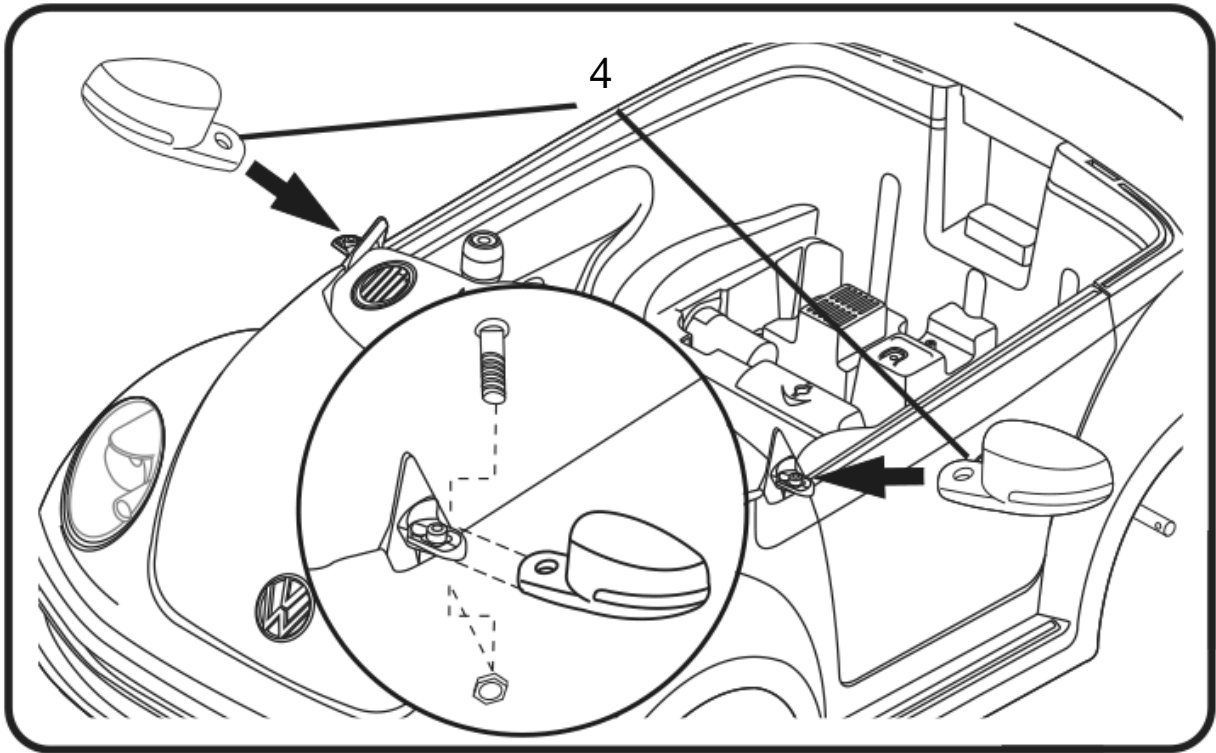

1. Remove the screw and nut from the mirror (4) before attaching.
2. Insert the left side mirror into the slot on the side of the body. Push it into the slot.
3. Insert the screw and fasten the nut to secure the mirror.
4. Repeat steps 1-3 for the right side mirror.

16 **Attach the Seat**

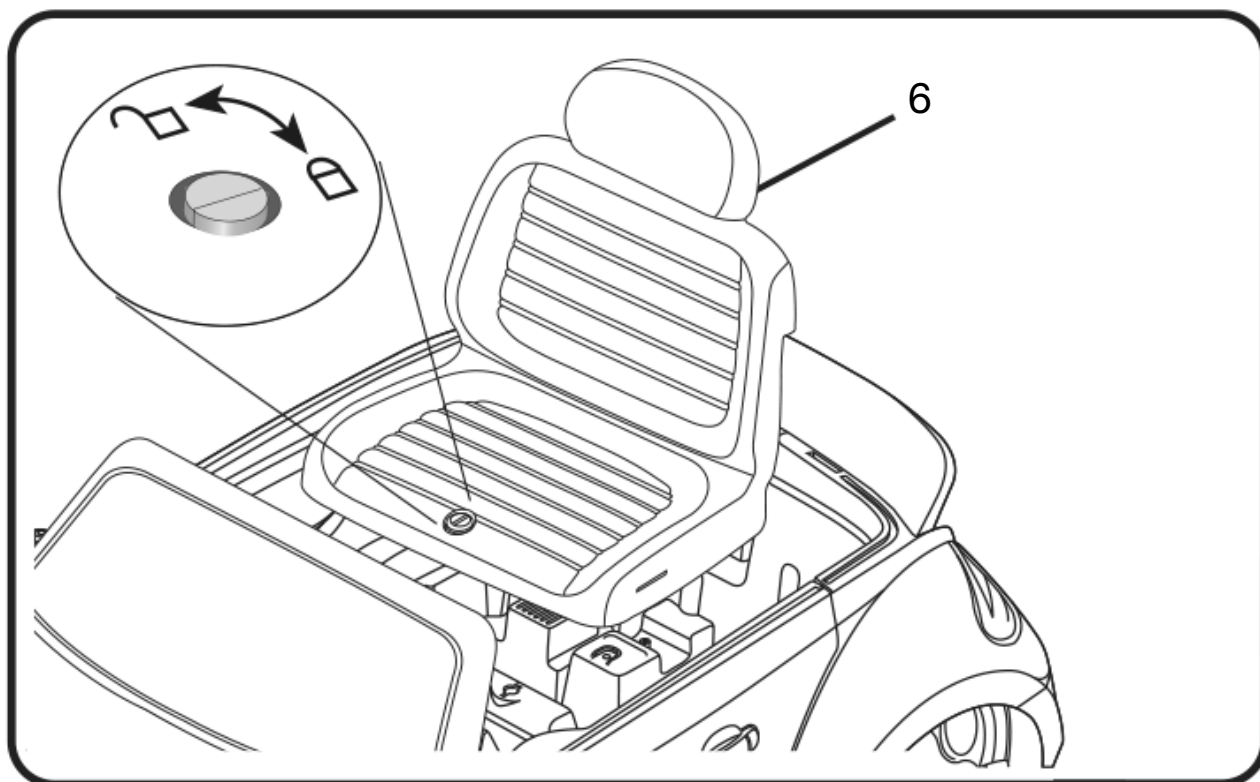

1. Position the seat (6) over the battery compartment.
2. Slide the seat onto the guides located in front of the rear spoiler.
3. Turn the thumb screw clockwise on the seat to lock it properly in position.

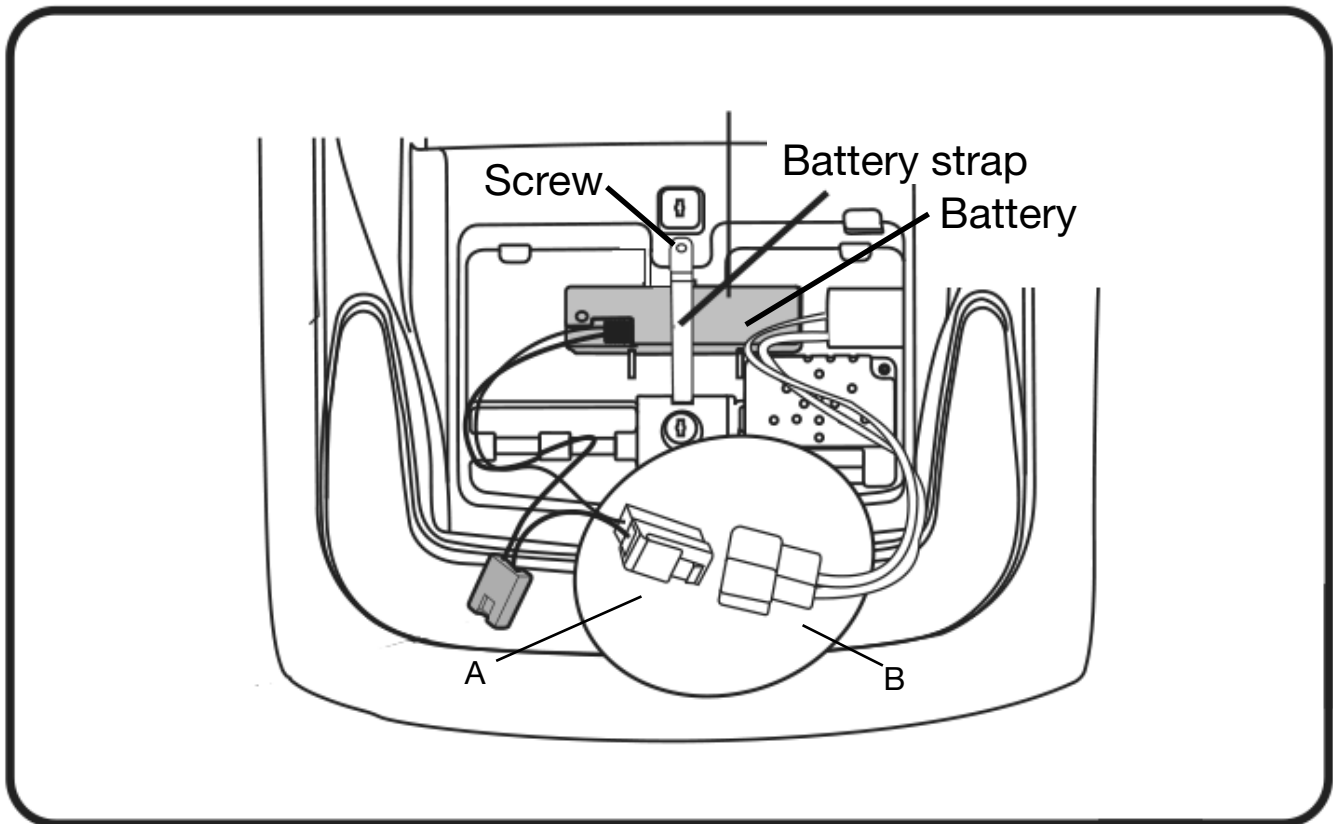

1. Disconnect the battery connector (A) from the engine connector (B) .
2. Loosen and remove the screw.
3. Unfasten the battery from the strap.
4. Remove the battery.

Note: It is not necessary to remove the battery for charging. However, if the battery does not reach the outlet, it can be removed for charging.

18 Operating Instructions

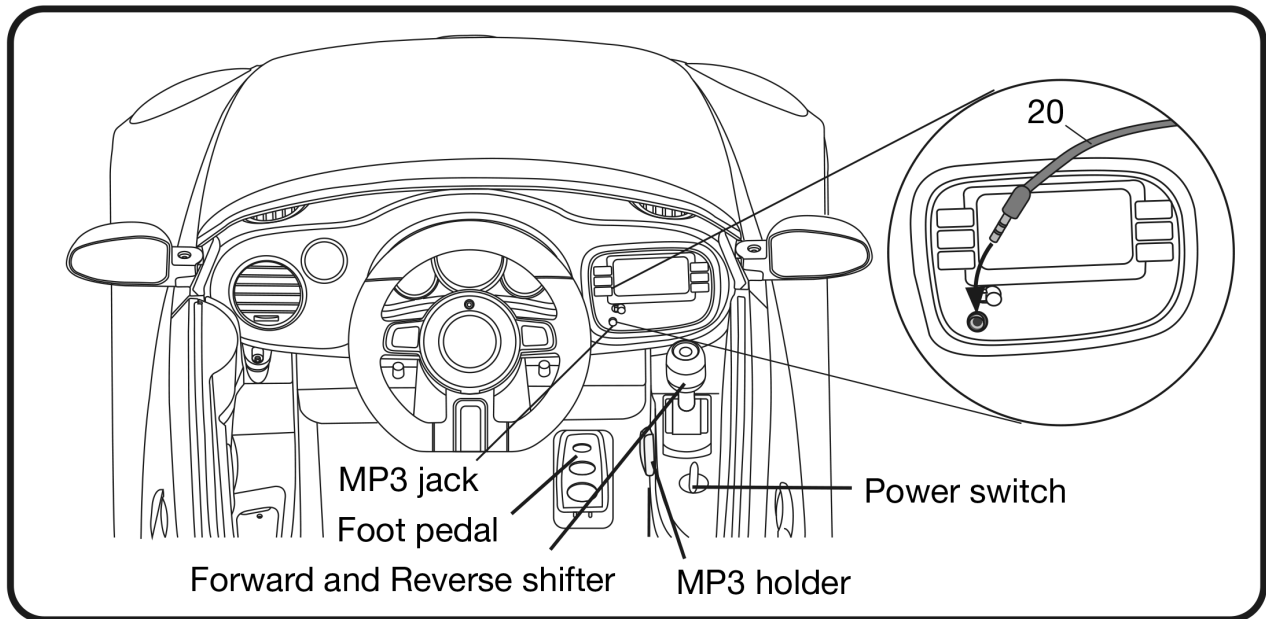

- To turn on the vehicle, turn the power switch to “I.” To turn off the vehicle, turn the power switch to “O.”
- Push the shifter forward to move forward. Pull the shifter backward to go in reverse.
- Insert the MP3 cable (20) into the MP3 jack and connect to your device. The MP3 player will turn off after about 1 hour. Press any button on the steering wheel to turn it on again. The car must be turned on to use.
- Press the foot pedal down to go. Release the foot pedal to stop.

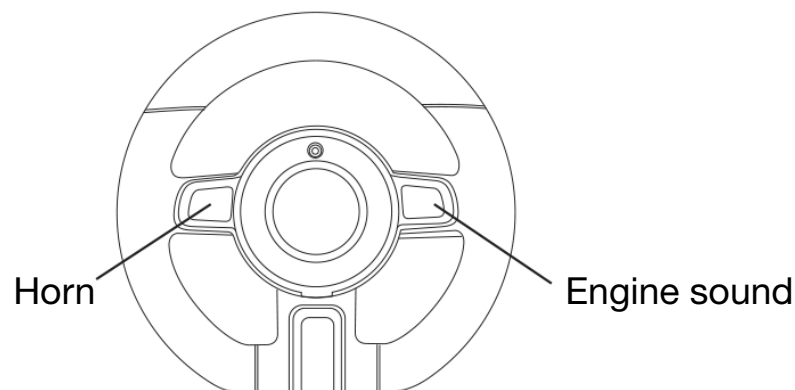

- Press the left and right buttons on the steering wheel to make sounds.
- Note: The steering wheel connector must be attached to the dashboard connector to make sounds. (See Page 14 for directions.)

Important Battery and Charger Information

- Only an adult who has read and understands the safety warnings may handle and operate the battery and battery charger. Keep away from children.
- Charge the battery for 24 hours before using the vehicle for the first time.
- Charge the battery immediately after each use. Charge for at least 8-12 hours, but no more than 20 hours.
- Charge the battery at least once a month, even if the vehicle is not used or stored.
- Never leave the battery in a discharged condition.
- Connect the terminal of the battery and charger, then plug the charger into a 120V AC outlet.
- It is normal for the charger to heat slightly. If the charger rises above 71°C / 160°F, disconnect the charger and call Customer Service for assistance.
- Keep the charger away from water or excessive moisture to prevent short-circuiting.
- Only use the charger specified with the original item. **Do not charge the battery with any other charger.**
- Do not attempt to recharge non-rechargeable batteries with the original charger.
- **Do not replace the battery with any other battery, or the warranty will be voided.** If you need a replacement battery, see Page 24 for replacement information.
- Remove damaged batteries from the car immediately. Recycle or dispose of the used batteries responsibly.
- Do not short circuit the supply terminals.
- Do not leave the battery connected in the vehicle for extended periods of time when the vehicle is not being used. Disconnect the battery connector from the engine connector before storing.
- The vehicle is equipped with a thermal fuse to protect the electric circuit. If the vehicle cuts out, turn the vehicle off and on to reset.

20 **General Care**

- Regularly inspect all vehicle parts to ensure they are in good working condition.
- Regularly inspect the charger, cord, plug, and other related parts for damage.
- Remove any damaged parts and immediately contact Customer Service for replacement parts. See Service and Repairs on Page 24 for more information.
- DO NOT operate the vehicle if there are any damaged parts.
- Carefully clean the vehicle with a damp cloth and mild soap. Do not get water in or near any electrical parts. Do not wash the vehicle with a hose.
- Store the vehicle indoors or use a tarp to cover it. Keep away from stoves, heaters, or other sources of heat.

Troubleshooting Guide 21

Completely read through the manual and troubleshooting guide before contacting Customer Service.

Problem	Potential Cause	Solution
Vehicle does not run	Battery is low	Recharge the battery
	Thermal fuse tripped	Reset fuse
	Snap pins are loose	Tighten snap pins
	Loose wires or loose connectors	Ensure the battery connectors are securely attached. If wires are loose, contact Consumer Service for repairs
	Battery is dead	Call Customer Service for replacement battery
	Electrical system is damaged	Call Customer Service for repairs
	Motor is damaged	Call Customer Service for repairs
Vehicle only runs for a short time	Undercharged battery	Ensure a secure connection when the battery is recharging. Recharge for at least 8-12 hours
	Overcharged battery	Never charge the battery for more than 30 hours
	Battery is old	Replace battery
Vehicle runs slowly	Battery is not fully charged	Ensure a secure connection when the battery is recharging
	Battery is old	Call Customer Service to order replacement battery
	Too much weight on vehicle	Reduce weight on vehicle (77 lbs max)
	Harsh conditions	Operate the vehicle on level ground and safe surfaces

Problem	Potential Cause	Solution
Vehicle needs a push to start	Loose wires or loose connectors	Ensure the battery connectors are securely attached. If wires are loose, contact Consumer Service for repairs
	“Dead spot” on motor	A “dead spot” means electricity is not being delivered to the terminal. Contact Consumer Service for repairs
Difficulty shifting	Attempting to shift while vehicle is moving	Stop the vehicle before shifting
Motor or gear box making grinding noises	Motor or gear damage	Contact Consumer Service for repairs
Battery will not recharge	Charger is not plugged in	Plug in the charger to a functional wall outlet
	Charger is not working	Call Consumer Service for a replacement
	Loose connector or loose adapter	Check that the connectors are securely plugged in to each other
Battery makes bubbling noise while recharging	This is normal	No action required
Charger is warm	This is normal	No action required

This device complies with part 15 of the FCC Rules. Operation is subject to the following two conditions: (1) this device may not cause harmful interference, and (2) this device must accept any interference received, including interference that may cause undesired operation.

This equipment has been tested and found to comply with the limits for a Class B digital device, pursuant to Part 15 of the FCC Rules. These limits are designed to provide reasonable protection against harmful interference in a residential installation.

This equipment generates, uses and can radiate radio frequency energy and, if not installed and used in accordance with the instructions, may cause harmful interference to radio communications. However, there is no guarantee that interference will not occur in a particular installation. If this equipment does cause harmful interference to radio or television reception, which can be determined by turning the equipment off and on, the user is encouraged to try to correct the interference by one or more of the following measures:

- Reorient or relocate the receiving antenna.
- Increase the distance between the equipment and the receiver.
- Consult dealer or an experienced radio/TV technician for help.
- Connect the equipment into an outlet on a circuit different from that to which the receiver is connected.
- Check the state or local requirements for the product before using the product.

Caution: Changes or modifications not expressly approved by the party responsible for compliance could void the user's authority to operate the equipment.

24 **Service and Repairs**

Do not return this vehicle to the store.

If your product requires service, repairs or replacement parts, please contact Aria Child Customer Service.

Hours: 9 AM - 5 PM (CST), Monday - Friday

Phone: 1-888-982-9309

Email: customerservice@ariachild.com

Web: www.ariachild.com

For a list of available replacement parts, please visit www.ariachild.com.

Aria Child™ 6-Volt Limited Warranty

- One-year limited warranty from the date of purchase with proof of purchase from an Aria Child certified retailer.
- Six month limited warranty on the 6-Volt battery with proof of purchase from an Aria Child certified retailer.
- This one-year limited warranty covers the ride-on vehicle against defects in materials and workmanship to the original purchaser. Proof of purchase receipt from an Aria Child certified reseller is required.
- Aria Child ensures the original 6-Volt battery is warranted for 6 months from initial purchase of the vehicle from a certified retailer. Proof of purchase receipt required.
- This warranty covers normal use and does not cover the Aria Child vehicle or battery if deemed damaged by unreasonable use, modification, neglect, accident, abuse, misuse, improper service or other causes not arising out of defects in materials or workmanship. Evidence of any attempt at consumer repair will void this warranty.
- This warranty does not cover, and is not intended to exclude any liability on the part of Aria Child, whether under this warranty or implied by law for any indirect or consequential damages for breach of warranty. Some states may not allow the exclusion or limitation so this limitation may not apply to you.

Should you need service or assistance with your vehicle during the warranty period:

- Please do not return vehicle to the store.
 - Consult the troubleshooting guide in this manual and online at www.ariachild.com
- or
- Call Aria Child Customer Service at 1-888-982-9309
 - Note: For any necessary repairs, the consumer will be responsible for freight charges to Aria Customer Service.

Note: This warranty gives you specific legal rights. You may also have other rights that may vary from state to state.

Please save your original sales receipt.

Product Registration 27

Fill out the form below and mail it to:

Aria Child, Inc.
680 N. Lakeshore Drive
Suite 1214
Chicago, IL 60611

OR fill out the form online at **www.ariachild.com**

We will use the information provided only for your warranty. We will not sell, rent or share your personal information.

Aria
Child_{INC} **Product Registration**

First Name: _____ Last Name: _____ Title: _____

Address: _____

City: _____ State: _____ Zip Code: _____

Email: _____ Phone: _____

Date of Purchase: _____

The following product information is on the cover of the owner's manual.

Product Name: _____ Model Number: _____

Serial Number: _____

Questions or comments? Contact us at www.ariachild.com or 1-888-982-9309

