



6V BMW i8 (5F62632)
Customer Service Guide



For internal reference only

Customer Service Guide



Contents

I) Check Battery	3
II) Check Wiring Condition	6
III) Check Foot Pedal	15
IV) Gearbox Replacement	17
V) Butterfly Door Replacement	24
VI) Warning Stickers	29
VII) Schematic diagram	35
VIII) Exploded View	36

CAUTION :

Disconnect the battery before proceed the checking and/or replacing processes

Customer Service Guide



I) Check Battery

Operation: Use a Flat head screwdriver, unlock and remove the seat. Locate the battery harness, unplug the connector then use a volt-meter to check battery condition at battery side.

Step (1)



Step (2)



Customer Service Guide



I) Check Battery

Step (3)

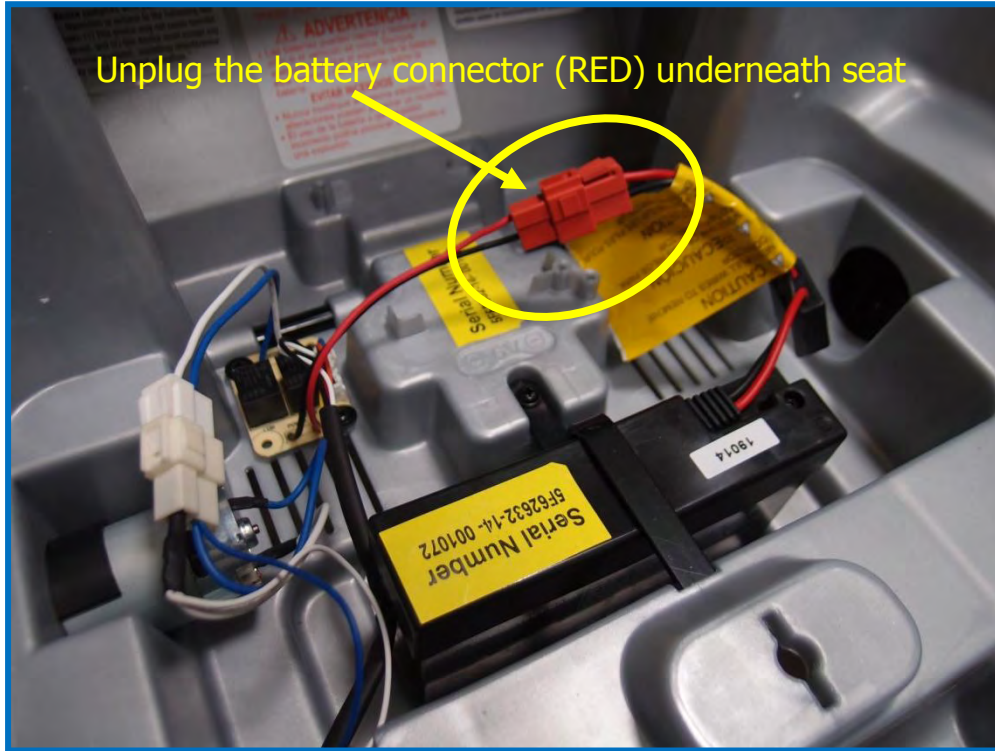

Step (4)



Customer Service Guide



I) Check Battery

Step
(5)



Reading Judgment: 6.0 V ~ 6.6 V – Good condition

5.6 V ~ 5.9 V – Proceed to Recharge

5.5 V – Battery to be recharged if after the stipulated recharging time, voltage has not increased, the Battery needs replacement

Below 5.5 V – Battery needs replacement

Customer Service Guide



II) Check Wiring Connection

Operation: There are totally two positions of connections should be checked.

A. Motor/Gearbox : Follow above (Point I) to remove the seat, locate the Gearbox harness underneath.



Customer Service Guide



II) Check Wiring Connection

B. Steering Wheel

Step (1)



Step (2)

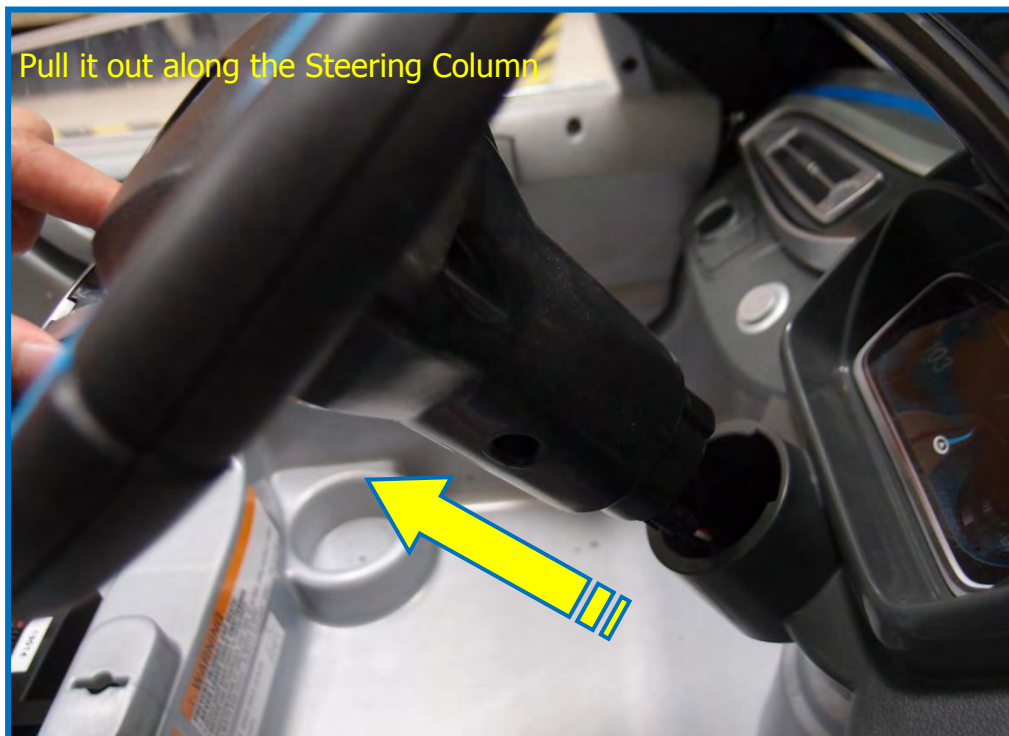

Customer Service Guide



II) Check Wiring Connection

Step
(3)



There is a connector for the sound effects of Steering Wheel

Unplug the connector and continuous below steps if you need to check the wiring inside Dashboard. Otherwise, reverse above procedures to re-assemble back the vehicle

Customer Service Guide



II) Check Wiring Connection

C. Other Connections : Access the circuitry inside Dashboard assembly to check other wiring connections, Steering Wheel should be removed first.

Step (1)



Step (2)



Customer Service Guide



II) Check Wiring Connection

Step (3)



Locate the two screws as pointed that secure the dashboard in place

Step (4)



Use Phillips screwdriver to unscrew and remove the dashboard

Customer Service Guide



II) Check Wiring Connection

Step (5)



Step (6)

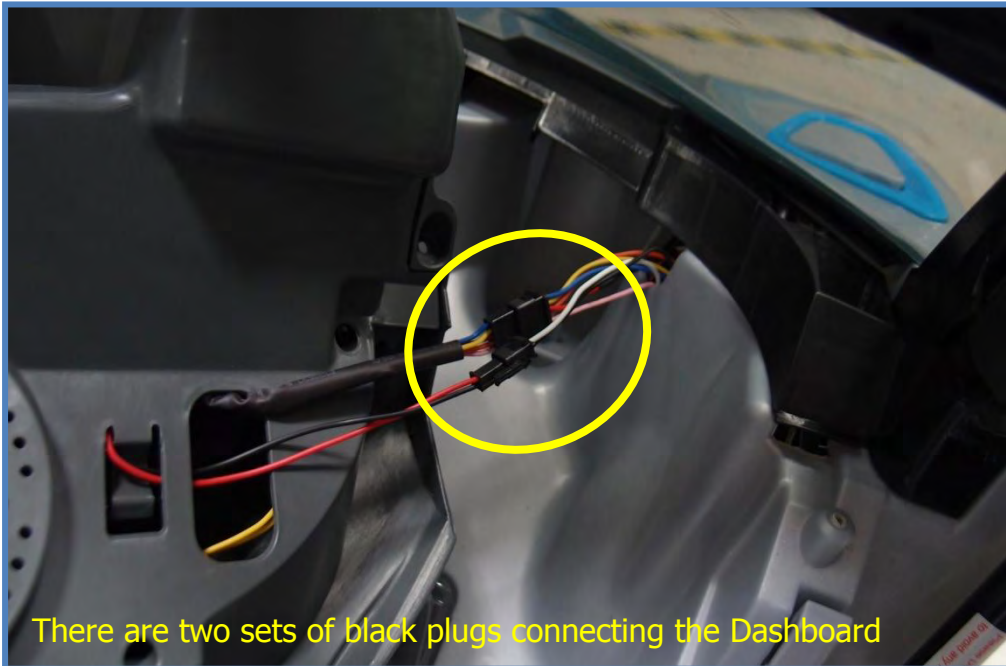

If the problem is address and fixed, reverse above steps to re-assemble the vehicle. Or unplug the connector and continuous as below steps when you need to further check the wiring inside Dashboard.

Customer Service Guide



II) Check Wiring Connection

Step (7)



Step (8)



Customer Service Guide



II) Check Wiring Connection

Step (9)

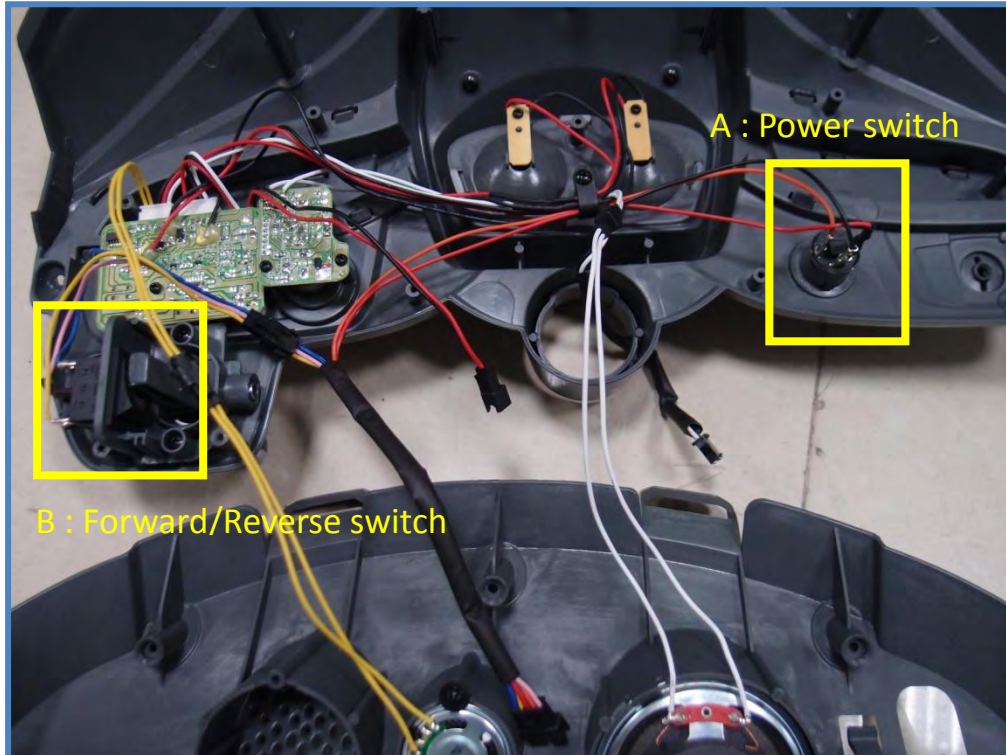

Step (10)

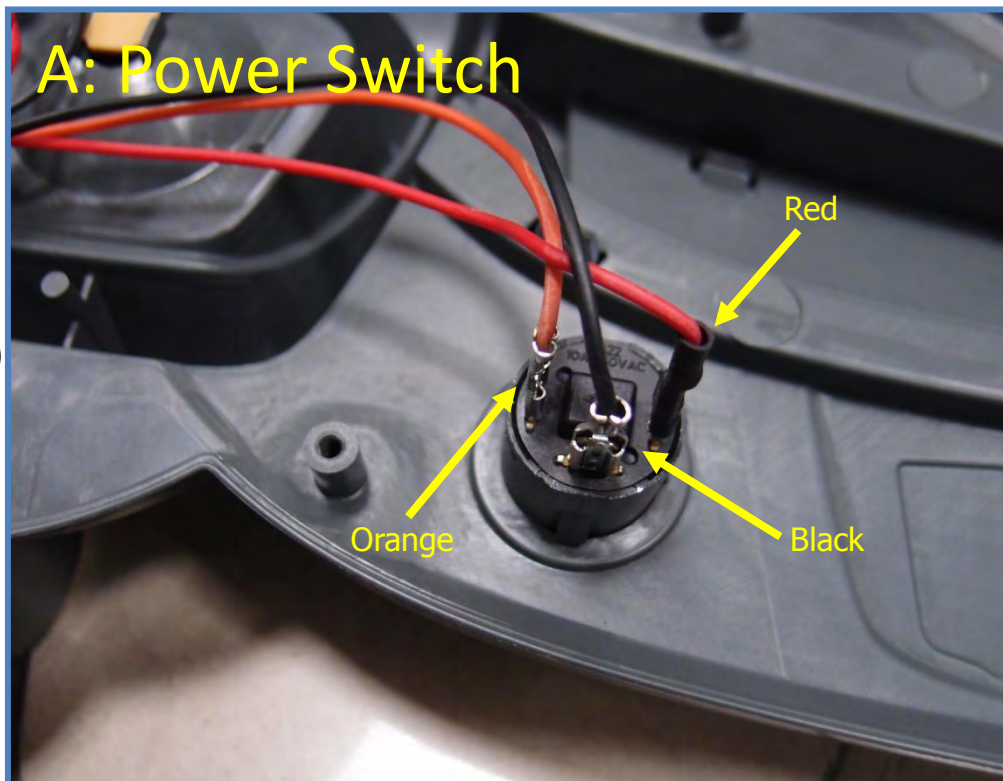

Customer Service Guide



II) Check Wiring Connection

Step
(11)

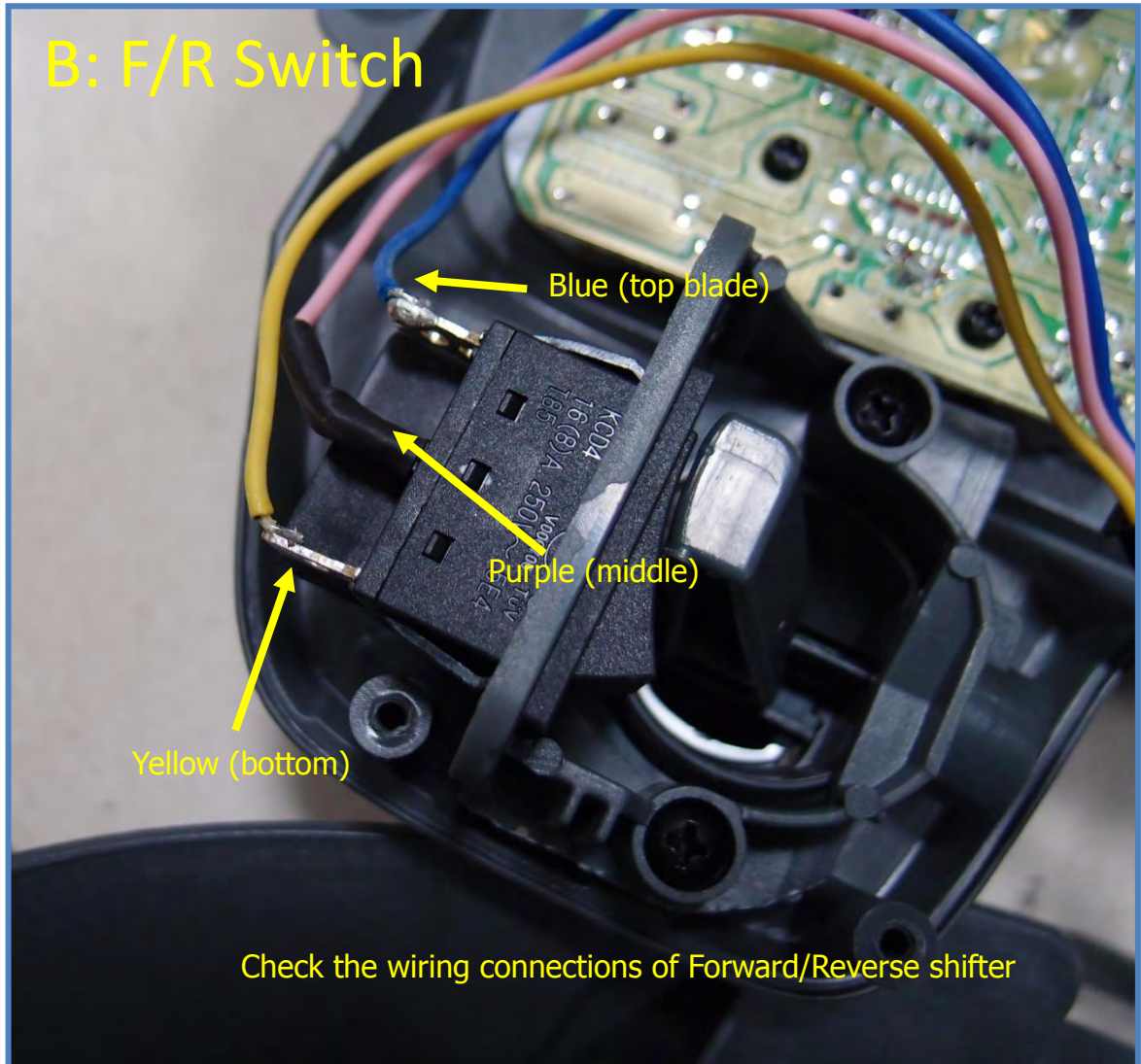

Reverse above procedures to re-assemble back the vehicle

Customer Service Guide



III) Check Foot Pedal

Operation: Follow below procedures to check the Foot Pedal connection.

Step (1)

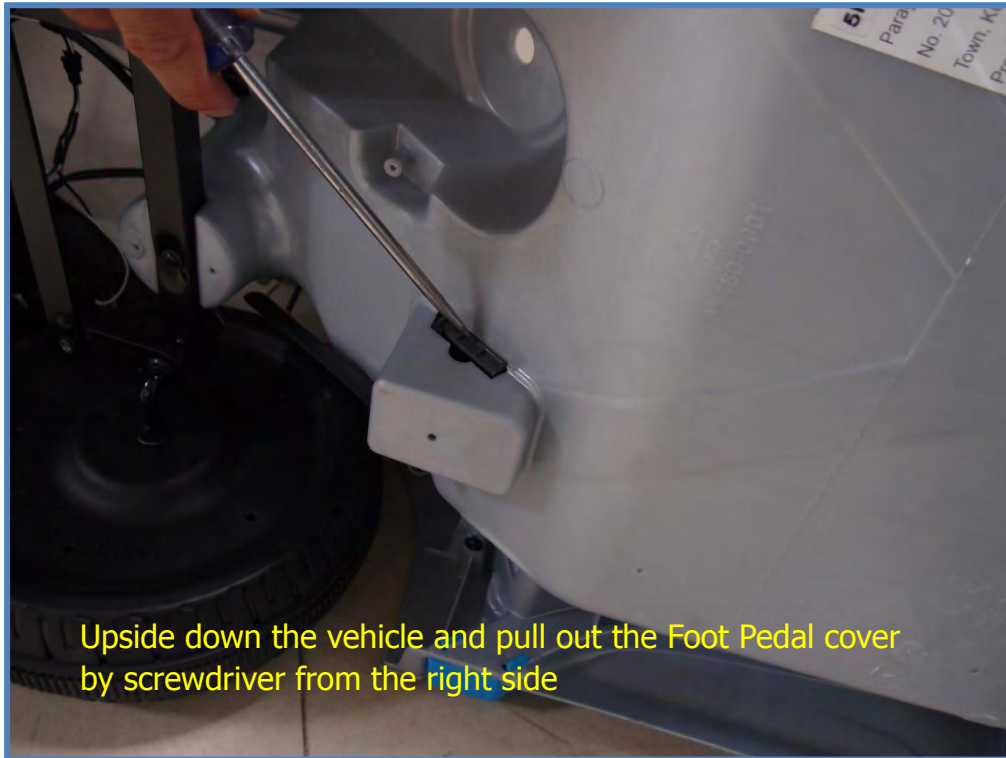

Step (2)

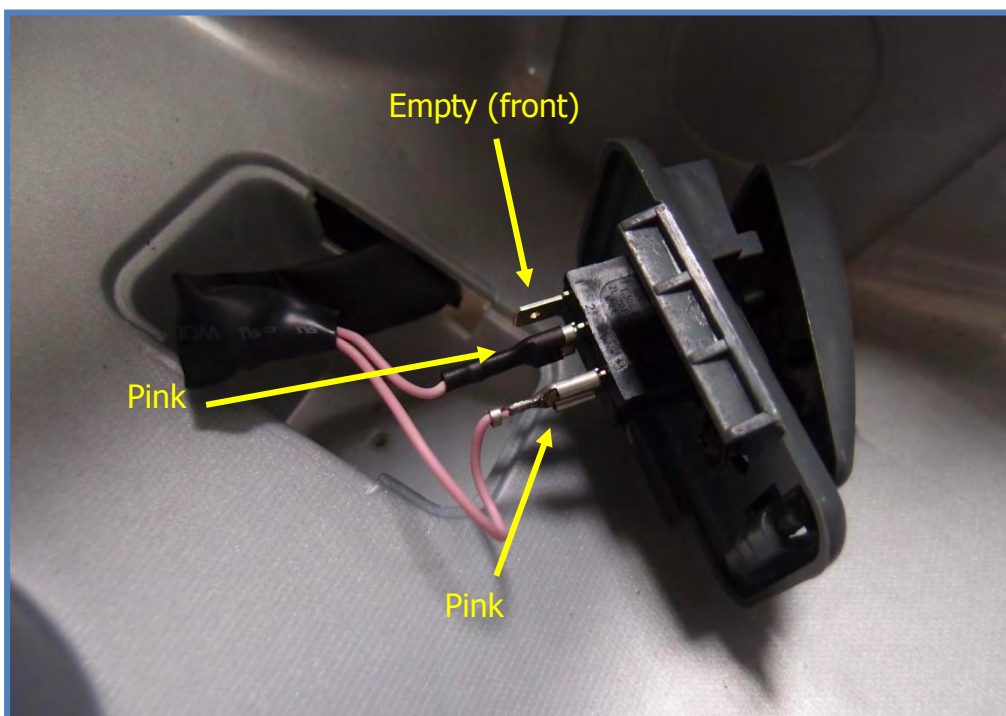

Customer Service Guide



III) Check Foot Pedal

Step
(3)

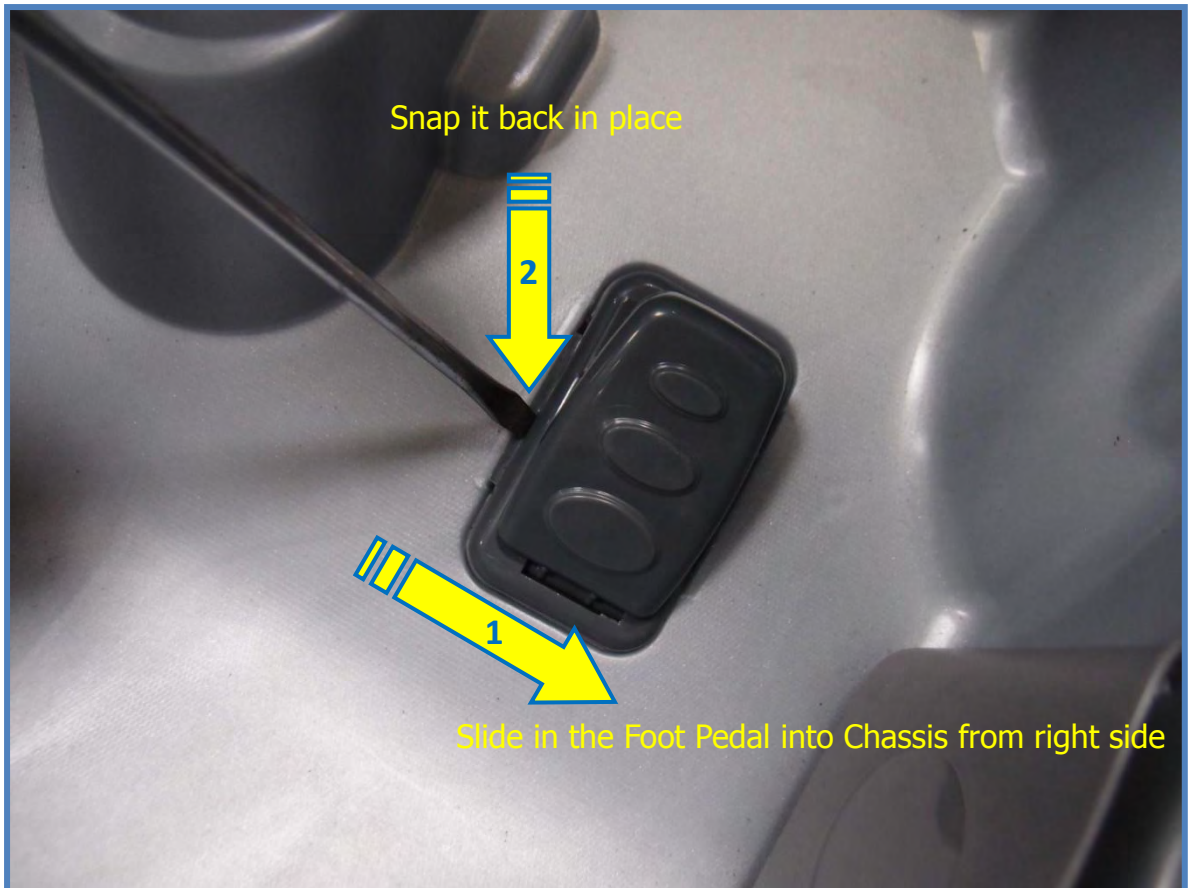

Customer Service Guide



IV) Gearbox Replacement

Operation: Follow below steps to take apart the gearbox completely for replacing.

Step (1)



Step (2)

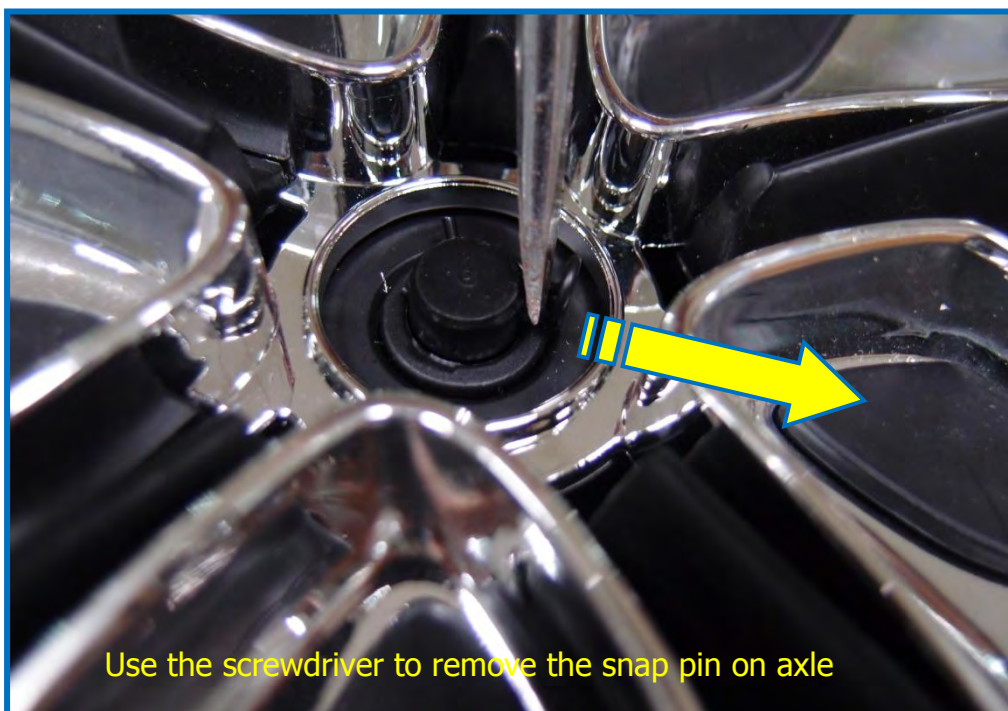

Customer Service Guide



IV) Gearbox Replacement

Step (3)



Step (4)



Customer Service Guide



IV) Gearbox Replacement

Step (5)



Step (6)



Customer Service Guide



IV) Gearbox Replacement

Step (7)



Step (8)

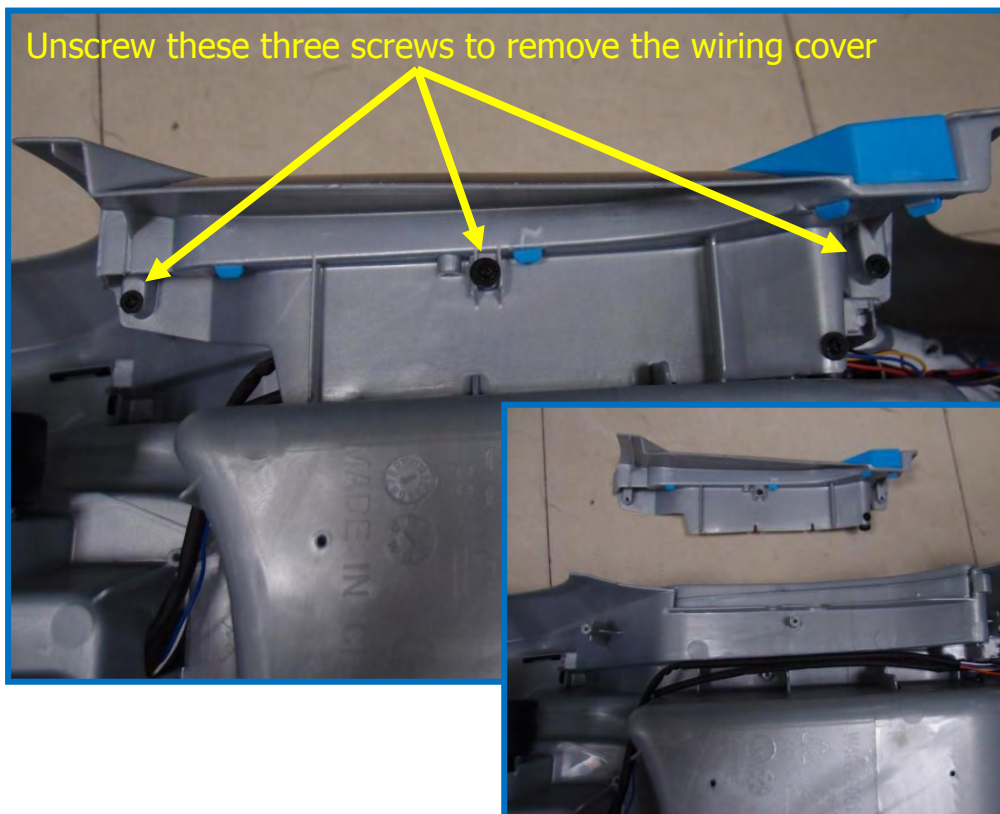

Customer Service Guide



IV) Gearbox Replacement

Step (9)

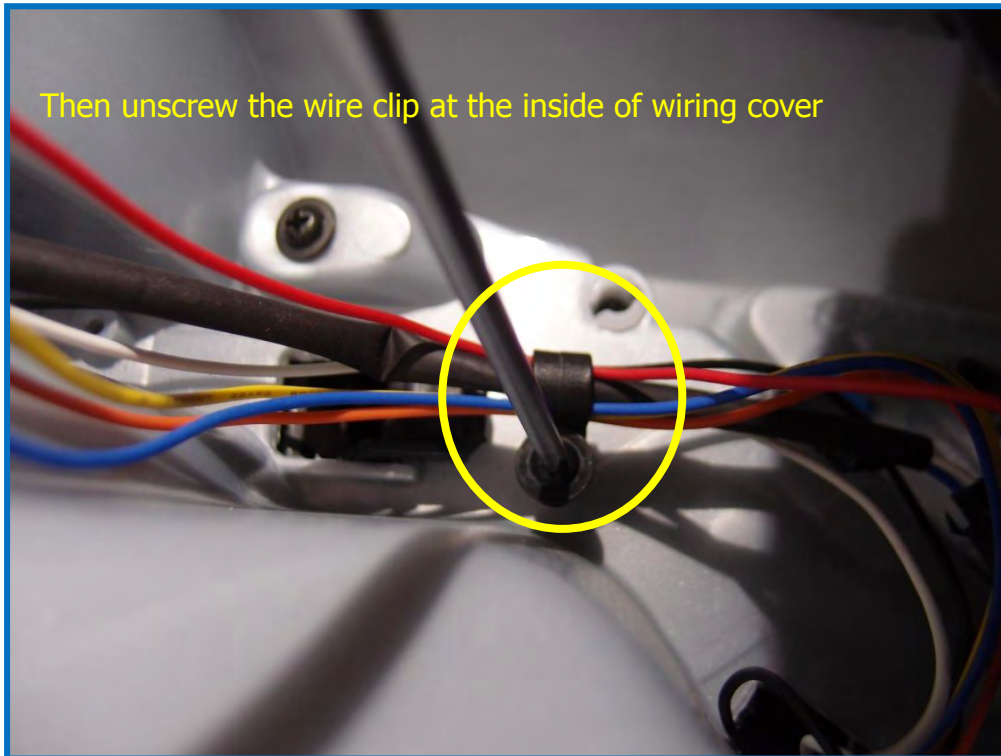

Step (10)



Customer Service Guide



IV) Gearbox Replacement

Step (11)



Reverse above procedures to re-assemble back the vehicle

Step (12)

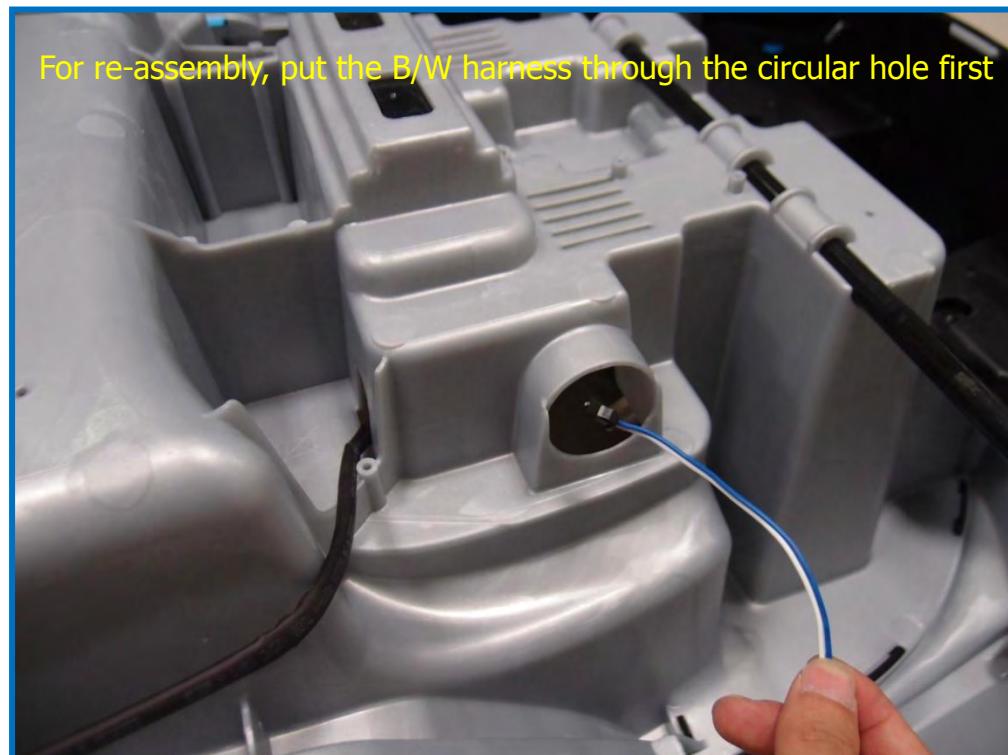

Customer Service Guide



IV) Gearbox Replacement

Step (13)

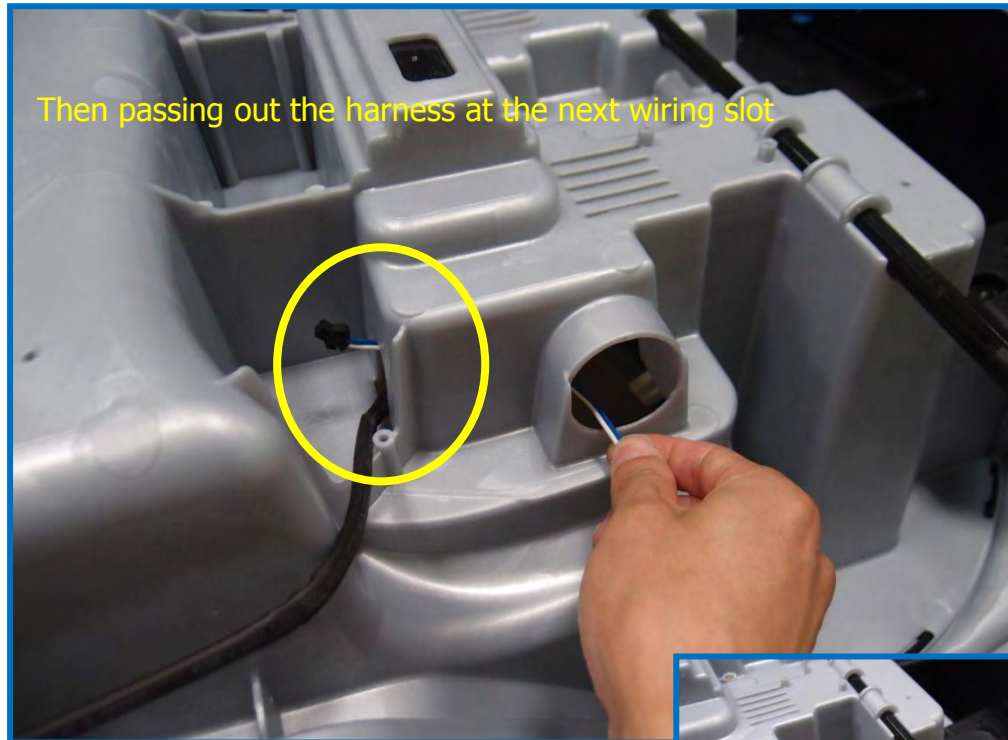

Step (14)



Customer Service Guide



V) Butterfly Door Replacement

Operation: Follow above Procedure (IIB) to remove the Steering Wheel first.

Step (1)



Unscrew the two screws at the inner side of windshield frame

Step (2)

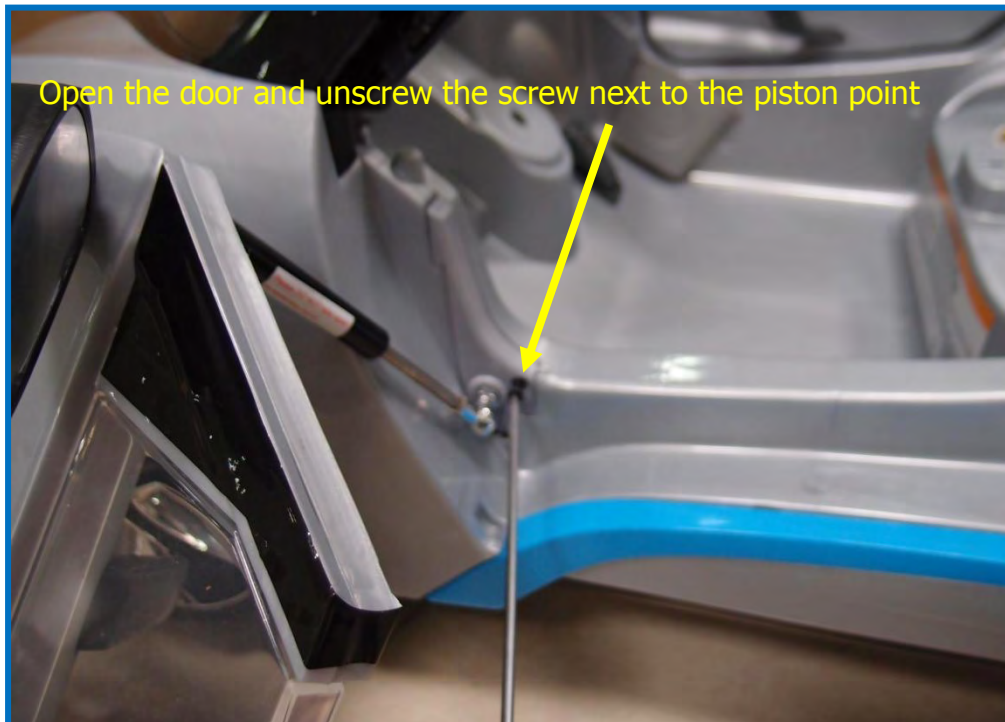

Open the door and unscrew the screw next to the piston point

Customer Service Guide



V) Butterfly Door Replacement

Step (3)



Step (4)

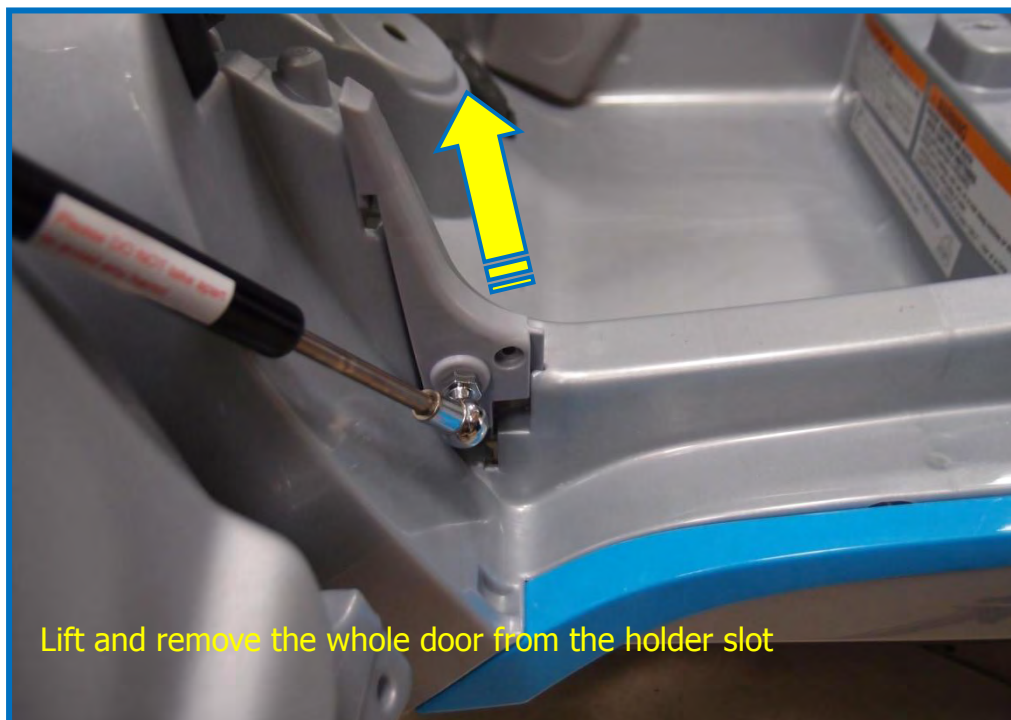

Customer Service Guide



V) Butterfly Door Replacement

Step (5)



Step (6)



Customer Service Guide



V) Butterfly Door Replacement

Step (7)

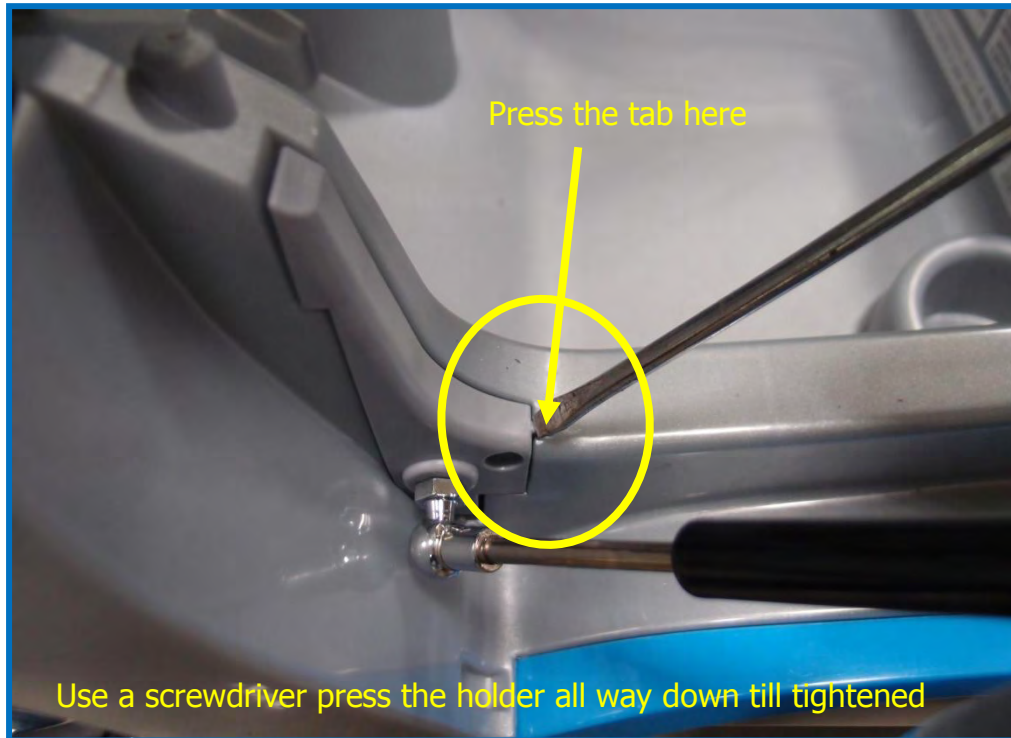

Step (8)

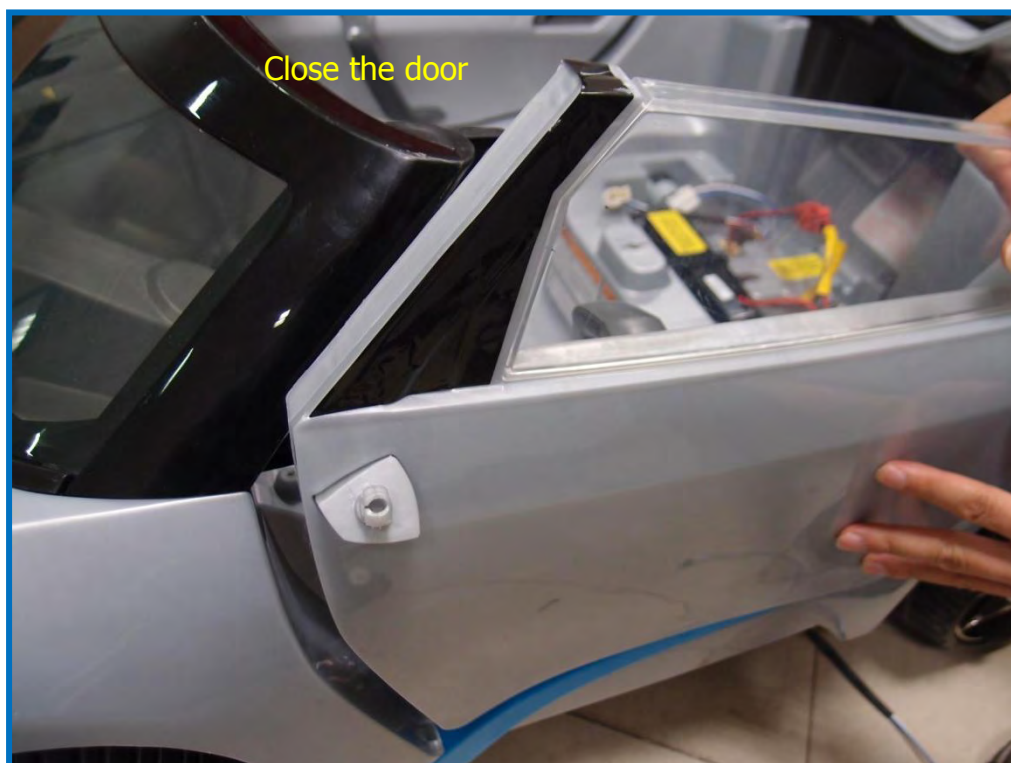

Customer Service Guide



V) Butterfly Door Replacement

Step
(9)

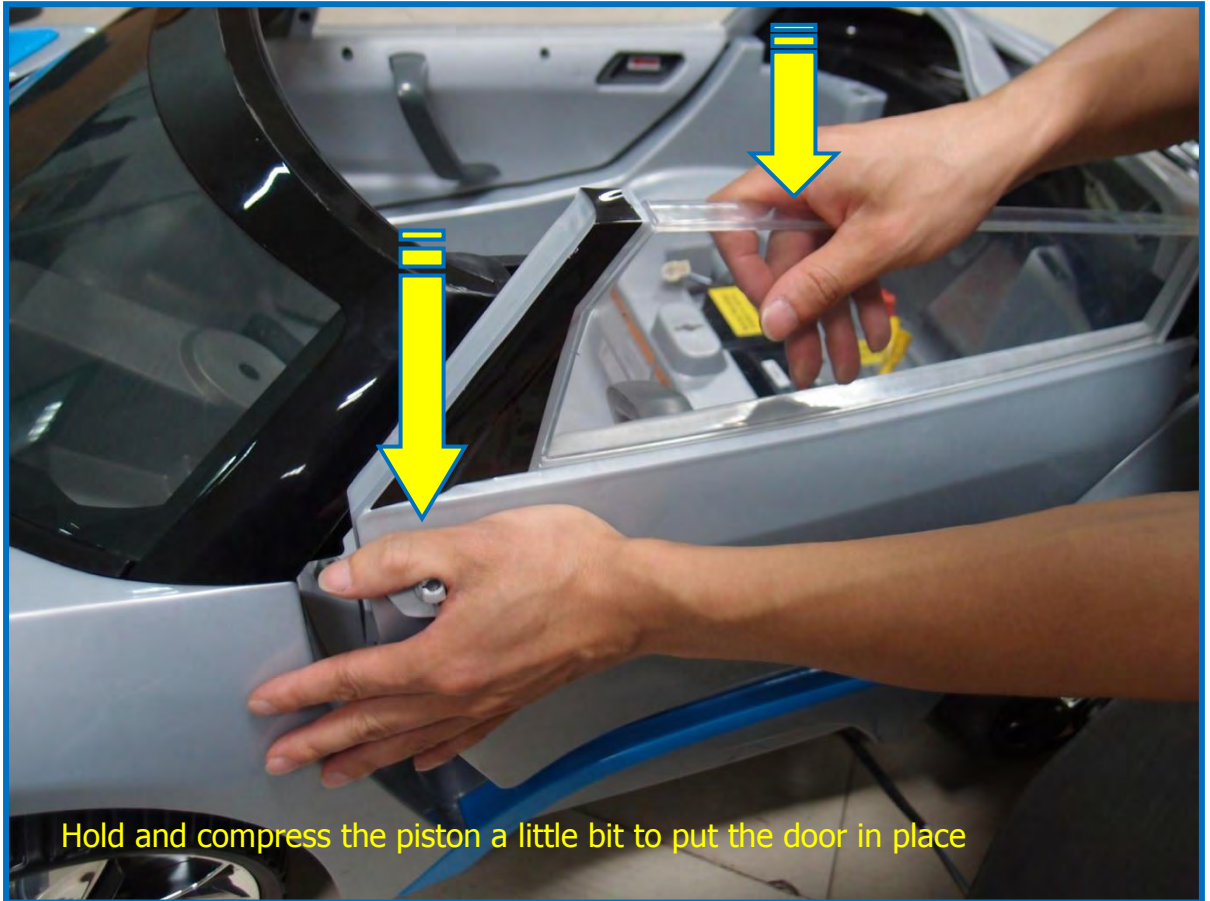

Reverse the screwing procedures to re-assemble back the vehicle

Customer Service Guide



VI) Warning Stickers

Operation: Check and re-put the damaged warning stickers after repairing.

(1) Behind the seat

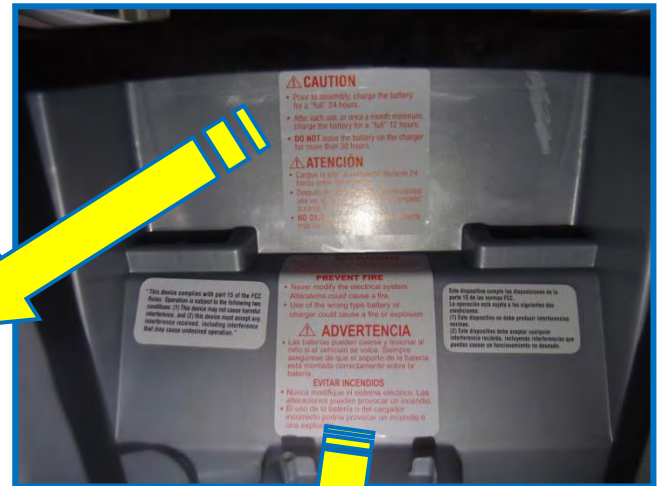

CAUTION

- Prior to assembly, charge the battery for a “full” 24 hours.
- After each use, or once a month minimum, charge the battery for a “full” 12 hours.
- **DO NOT** leave the battery on the charger for more than 30 hours.

ATENCIÓN

- Cargue la pila "al completo" durante 24 horas antes del montaje.
- Después de cada utilización, o como mínimo una vez al mes, cargue la pila "al completo" durante 12 horas.
- **NO DEJE** la pila en el cargador durante más de 30 horas.

WARNING

- Batteries can fall out and injure a child if vehicle tips over. Always be sure the battery bracket is properly assembled over battery.

PREVENT FIRE

- Never modify the electrical system. Alterations could cause a fire.
- Use of the wrong type battery or charger could cause a fire or explosion.

ADVERTENCIA

- Las baterías pueden caerse y lesionar al niño si el vehículo se volca. Siempre asegúrese de que el soporte de la batería está montada correctamente sobre la batería.

EVITAR INCENDIOS

- Nunca modifique el sistema eléctrico. Las alteraciones pueden provocar un incendio.
- El uso de la batería o del cargador incorrecto podría provocar un incendio o una explosión.

Customer Service Guide



VI) Warning Stickers

(1) Behind the seat

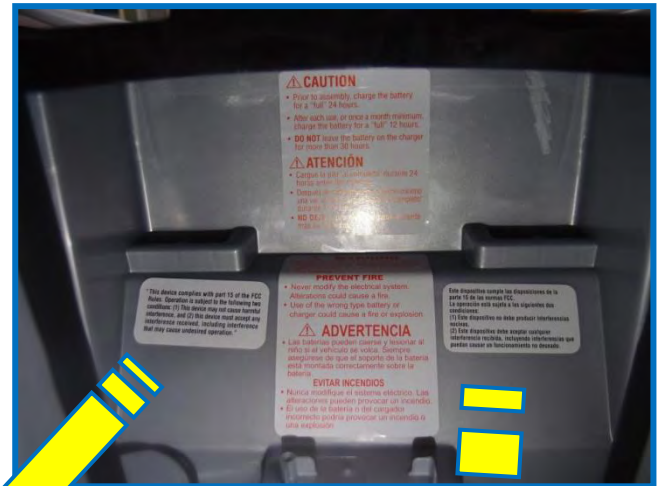

“This device complies with part 15 of the FCC Rules. Operation is subject to the following two conditions: (1) This device may not cause harmful interference, and (2) this device must accept any interference received, including interference that may cause undesired operation.”

Este dispositivo cumple las disposiciones de la parte 15 de las normas FCC. La operación está sujeta a las siguientes dos condiciones:

- (1) Este dispositivo no debe producir interferencias nocivas.**
- (2) Este dispositivo debe aceptar cualquier interferencia recibida, incluyendo interferencias que puedan causar un funcionamiento no deseado.**

Customer Service Guide



VI) Warning Stickers

(2) Below the seat



For questions or comments please call 888-982-9309
or visit our website at www.ariachild.com



Customer Service Guide



VI) Warning Stickers

(2) Below the seat



¡ADVERTENCIA!

EVITE LESIONES Y PELIGROS FATALES: •NUNCA DEJE SOLO AL NIÑO.

- Es **NECESARIA** la vigilancia directa de un adulto.
- No permita **NUNCA** que se use en la calle, en las proximidades del tránsito de vehículos, en cuestas pronunciadas o sobre peldaños, ni cerca de piscinas (albercas) u otras acumulaciones de agua. • El niño **SIEMPRE** debe usar zapatos.
- **SIEMPRE** siéntese en el asiento • **SOLO** 1 jinete a la vez.

Customer Service Guide



VI) Warning Stickers

(2) Below the seat

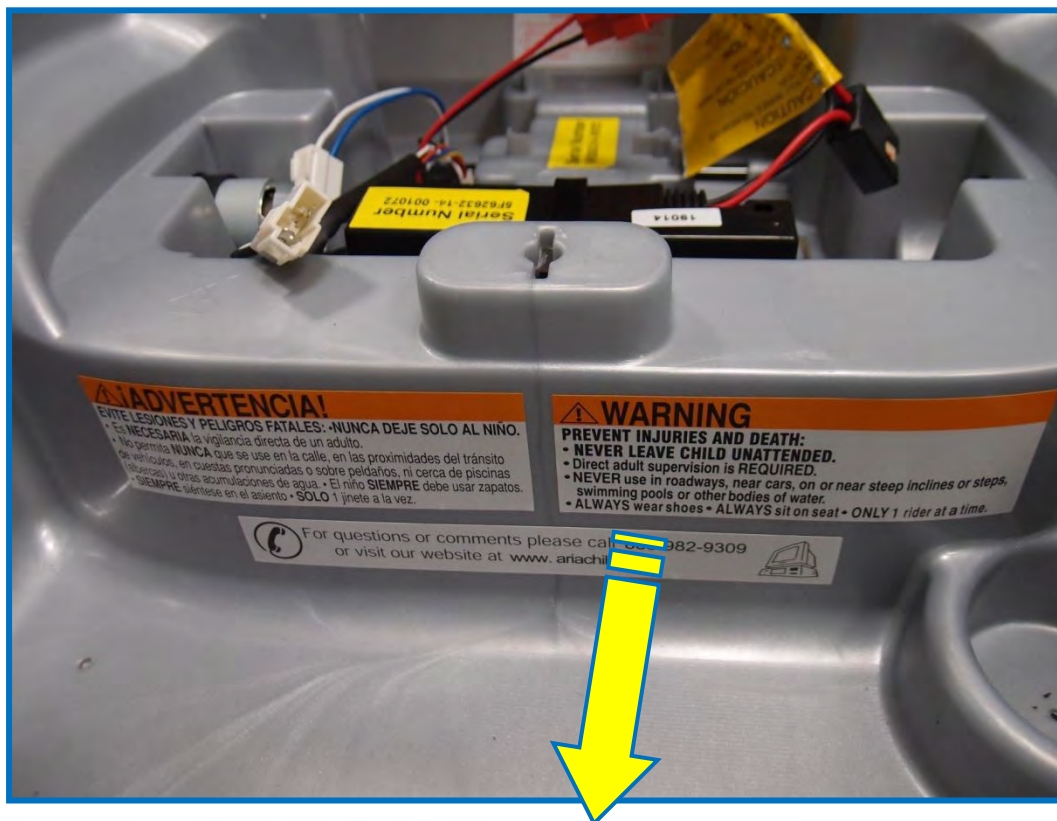

WARNING

PREVENT INJURIES AND DEATH:

- **NEVER LEAVE CHILD UNATTENDED.**
- Direct adult supervision is **REQUIRED.**
- **NEVER** use in roadways, near cars, on or near steep inclines or steps, swimming pools or other bodies of water.
- **ALWAYS** wear shoes • **ALWAYS** sit on seat • **ONLY** 1 rider at a time.

Customer Service Guide



VI) Warning Stickers

(3) Battery harness

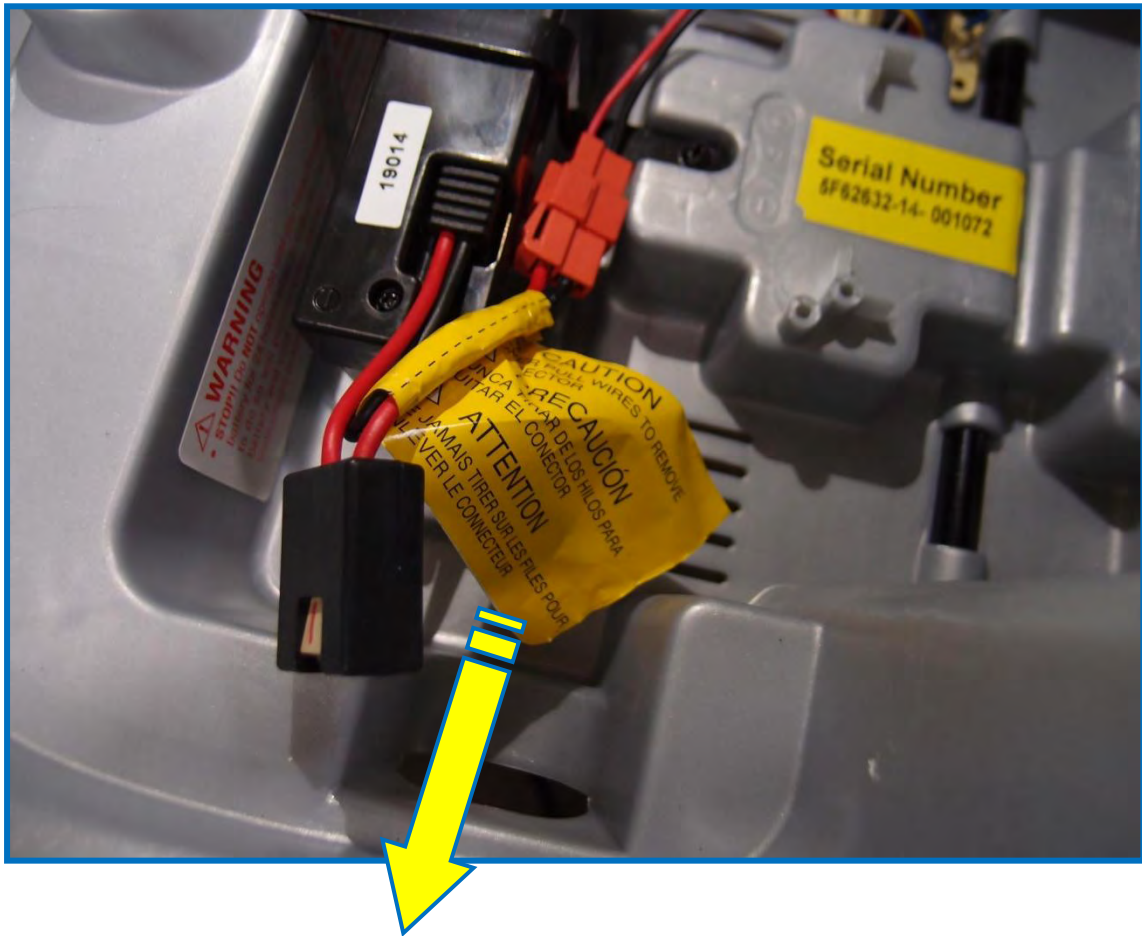

<p>CAUTION ⚠ NEVER PULL WIRES TO REMOVE CONNECTOR</p> <p>PRECAUCIÓN ⚠ NUNCA TIRAR DE LOS HILOS PARA QUITAR EL CONECTOR</p> <p>ATTENTION ⚠ NE JAMAIS TIRER SUR LES FILS POUR ENLEVER LE CONNECTEUR</p>	<p>CAUTION ⚠ NEVER PULL WIRES TO REMOVE CONNECTOR</p> <p>PRECAUCIÓN ⚠ NUNCA TIRAR DE LOS HILOS PARA QUITAR EL CONECTOR</p> <p>ATTENTION ⚠ NE JAMAIS TIRER SUR LES FILS POUR ENLEVER LE CONNECTEUR</p>
--	--

Customer Service Guide



VII) Wirings Schematic

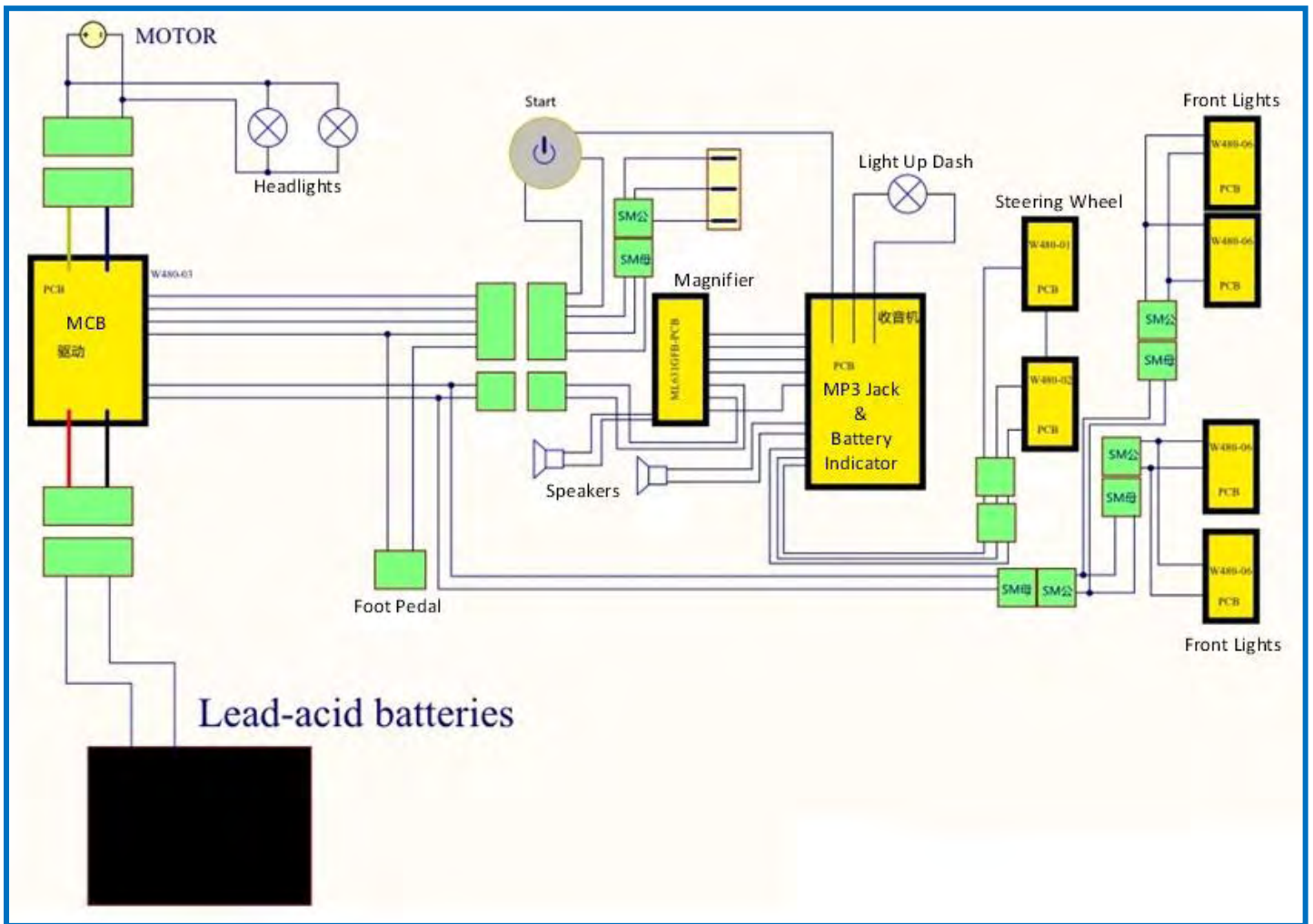

Customer Service Guide



VIII) Exploded View

