

MOTORIZED

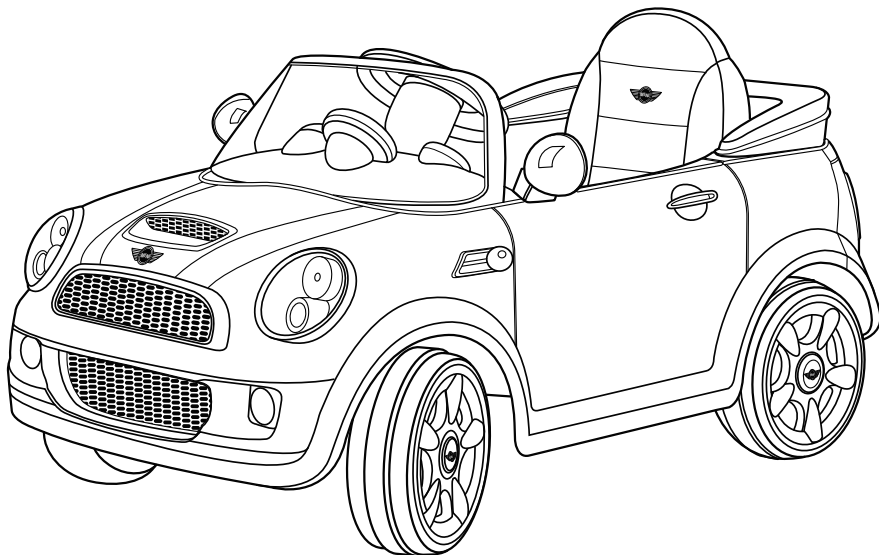

If you are experiencing any difficulties with this product, **DO NOT RETURN THE PRODUCT DIRECTLY TO THE STORE.** Please contact Hunter Products Customer Service at **www.electricrideon.com.au** or **Toll Free Number 1800 224 094** for service assistance.



MINI COOPER_S

Owner's Manual and Assembly Instructions

Model W446AL

Read and understand the entire manual before assembly and operation. The vehicle must be assembled by an adult who has read and understands the instructions.

Made in China.

Save this manual with your sales receipt.



MINI COOPER S manufactured by Paragon Child Products Co.Ltd,(Goodbaby Group), No.20 Lufeng East Road, Lujia Town, Kunshan City, Jiangsu Province, China. The MINI trademarks are used under license from BMW AG. MINI name and associated logos are trademarks of BMW AG.

Thank You

Thank you for purchasing the Mini Cooper S. With the Mini Cooper S your child will have fun and enjoyment for years to come. Some of the features on the Mini Cooper S include: forward and reverse switch, lights and engine sounds. Please contact Hunter Products Pty Ltd at www.electricrideon.com.au or Call at **1800 224 094** (local call cost) with comments or questions.

WARNING!

PREVENT INJURIES AND DEATHS:

- **NEVER LEAVE CHILD UNATTENDED. ALWAYS** keep child in view when child is in vehicle. Direct adult supervision is **REQUIRED**.
- **NEVER** use roadways, near cars, on or near steep inclines or steps, swimming pools or other bodies of water.
- **ALWAYS** wear shoes.
- **ALWAYS** sit on the seat.
- **NEVER** allow more than one (1) riders in the MINI Cooper S.
- **RISK OF FIRE.** Do not bypass.

Contents

| | |
|--|-----------|
| Safety | 1 |
| User Requirements | 2 |
| Charging the Battery: Warnings | 3 |
| Parts | 5 |
| Assembly | 6 |
| Install the Front Wheels | 7 |
| Install the Rear Wheels | 8 |
| Attaching the Steering Wheel | 9 |
| Assemble the Speedometer and Windshield | 10 |
| Assemble Soft Roof and Mirror | 11 |
| Attach the Remote Control batteries | 12 |
| Remote Control Operation | 13 |
| Maintenance | 14 |
| General | 14 |
| Battery | 14 |
| Troubleshooting Guide | 19 |
| Services Repairs and Parts | 21 |
| Warranty | 22 |

Safety

WARNING!

The following safety hazards may result in serious injury or death to the user of the MINI Cooper S:

- This product contains small parts that are for adult assembly only. Keep small children away when assembling. Remove and dispose of all protective material and poly bags before assembly. Be sure to remove all packaging materials and parts from underneath the car body.
- Riding the vehicle without a helmet. Riders must always wear a fitted helmet that complies with Australian Standard **AS/NZS 2063:2008**.
- Battery posts, terminals and related accessories contain lead and lead compounds (acid) chemicals that are toxic and corrosive. Never open the battery.
- Body parts such as hands, legs, hair and clothing can get caught in moving parts. Never place a body part near a moving part or wear loose clothing while using the vehicle. Always wear shoes when using the vehicle.
- Using the vehicle near streets, motorvehicles, drop-offs such as: steps, water (swimming pools) or other bodies of water, sloped surfaces, hills, wet areas, flammable vapors, in alleys, at night or in the dark could result in an unexpected accident. Always use the vehicle in a safe, secure environment with continuous adult supervision.
- Using the vehicle in unsafe conditions such as snow, rain, loose dirt, mud, sand or fine gravel may result in unexpected action such as tip over and skidding.
- Using the vehicle in an unsafe manner. Examples include but are not limited to:
 - Pulling the vehicle with another vehicle or similar device
 - Allowing more than two riders
 - Pushing the user from the back
 - Traveling at an unsafe speed
- Always use common sense and safe practices when using the vehicle.
- Store the vehicle indoors or cover it with a tarp to protect it from weather. Do not wash the car with a hose or soap and water. Water will damage the motor, electric system, and battery.

User Requirements

| | |
|---------------------|----------------------------|
| Age Range | 3 and 7 years |
| Weight Range | No more than 77 lbs (35kg) |

Before using the MINI Cooper S the child should understand the vehicle controls and safety issues. They must also demonstrate the capability to handle the vehicle and operate its controls. It is the responsibility of the adult to educate the child and supervise the vehicles use.

Read the following safety warnings to any child using the MINI Cooper S Spyder Ride-on:

WARNING!

- Only use the vehicle when an adult is present to watch (supervise).
- Always sit in the seat when using the vehicle.
- Keep your hands, hair and clothes away from moving parts.
- Always wear shoes when using the vehicle.
- Only one rider is allowed at a time on the MINI Cooper S Spyder Ride-on.
- Children under three years old cannot use the vehicle.
- Only drive on level ground.
- Do not go near water, drop-offs or up and down steep slopes.
- Do not drive the vehicle into loose dirt, mud, sand or fine gravel.
- Do not drive the vehicle on streets or near cars.

Charging the Battery: Warnings

WARNING!

The following safety hazards may result in serious injury or death to the user of the MINI Cooper S:



- Use of a battery or charger other than the supplied 6v rechargeable battery and charger may cause a fire or explosion. Only use the supplied 6v rechargeable battery and charger with the vehicle.
- Using the 6v rechargeable battery and charger for any other product may result in over heating, fire or explosion. Never use the 6v rechargeable battery and charger with another product.
- Explosive gases are created during charging. Charge the battery in a well ventilated area. Do not charge the battery near heat or flammable materials.
- Contact between the positive and negative terminals may result in fire or explosion. Avoid direct contact between the terminals. Picking up the battery by the wires or charger can cause damage to the battery and may result in a fire. Always pick up the battery by it's case or handles.
- Liquids on the battery may cause fire or electric shock. Always keep all liquids away from the battery and keep the battery dry.



- Contact or exposure to battery leakage (lead acid) may cause serious injury. If contact or exposure occurs immediately call your physician. If the chemical is on the skin or in the eyes, flush with cool water for 15 minutes. If the chemical was swallowed, immediately give the person water or milk. Do not give water or milk if the patient is vomiting or has a decreased level of alertness. Do not induce vomiting.

! WARNING!

- Battery posts, terminals and related accessories contain **lead and lead compounds (acid)**, chemicals and are toxic and corrosive. Never open the battery.



- Tampering or modifying the electric circuit system may cause a shock, fire or explosion and permanently damage the system. Exposed wiring, circuitry in the charger may cause electric shock. Always keep the charger housing closed.

Important! Before using the MINI Cooper S for the first time the battery needs to be charged for a full twenty-four hours (no more than thirty hours). Only an adult who has read and understands the following safety warnings should handle, charge or recharge of the battery (see Maintenance).

Note: It is not necessary to remove the battery from the vehicle for charging. However, if the adapter cord will not safely reach a 240V wall outlet, the battery can be removed for charging (see page 6 for instructions concerning battery replacement).

Parts

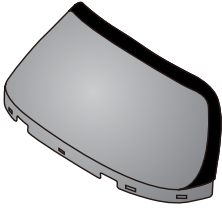

windshield

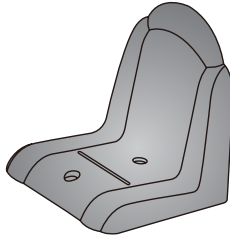

seat

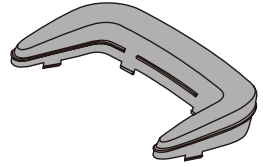

soft top

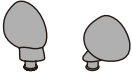

mirrors (L & R)



speedometer

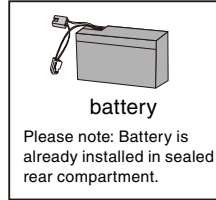

battery

Please note: Battery is already installed in sealed rear compartment.



remote controller

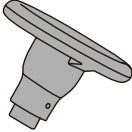

steering wheel

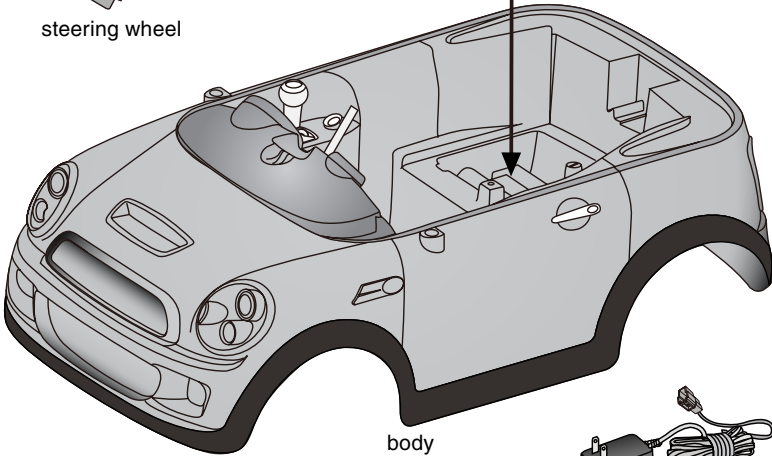

body

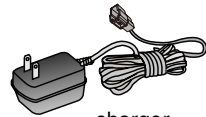

charger



front wheel x2



rear wheel x2



wheel cover x4



hub cap x4

Charge Battery Before Assembly

ONLY AN ADULT CAN CHARGE AND RECHARGE THE BATTERY.

NOTE: It is not necessary to remove the battery from the vehicle for charging. However, if the adapter cord will not safely reach a 240-volt wall outlet, the battery can be removed for charging.

Connect Charger to Battery

1. Use a flathead screwdriver to unlock the screws. Lift seat (Figure 1).
2. Unplug the engine connector from the battery (Figure 2).

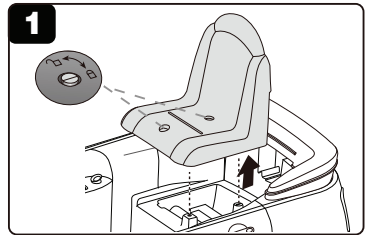

3. Plug the charger connector into the battery (Figure 3).

Use **ONLY** the 6-volt charger included with the Mini Cooper S.

Input: AC 240V, 50Hz

Output: DC 7.0V, 0.8A

4. Plug the charger into a standard 240-volt wall outlet (Figure 4). The charger may feel warm during charging. This is normal and not a cause for concern.

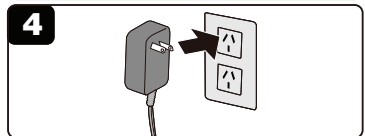
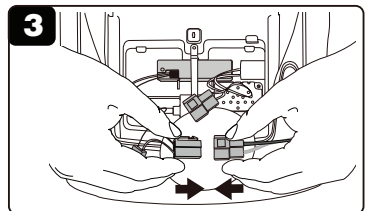
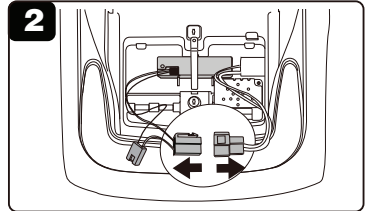

Disconnect Charger from Battery

1. Unplug the charger from the wall outlet.
2. Unplug the charger connector from the battery.
3. Plug the engine connector into the battery.
4. Position the seat over the battery. Lower the seat hooks into the holes (at front of seat). Lock seat screws (Figure 1).

Install the Front Wheels

1. Slide large washer onto axle as shown.
2. Locate a wheel marked **front**. Slide the wheel onto the axle with the word **front** facing in, towards the vehicle.
3. Align the five posts on the back of the wheel cover with the holes in the wheel and slide the wheel cover into the wheel.
4. Slide a small washer and then the snap-pin onto the axle.
5. Align the locks in the hubcap with the holes in the wheel cover and press in place.

NOTE: Do not use a hammer. Repeat steps 1-5 to attach both front wheels.

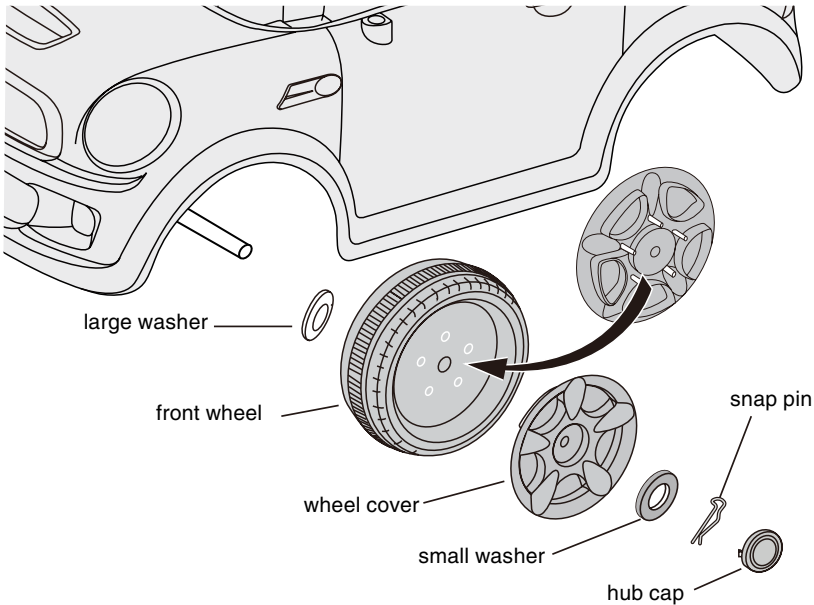

Install the Rear Wheels

1. Locate a wheel (marked “rear” with gear shaped protrusion).
2. Slide the wheel onto the axle with protrusion facing toward the vehicle.
3. Fit the gear shape protrusion into the gear box.
4. Align the five locating pins on the inside of the wheel cover into the wheel holes, and push the wheel cover into place.
5. Slide a small washer and then the snap-pin onto the axle.
6. Align the locks in the hubcap with the holes in the wheel cover. Press the hubcap into place.

NOTE: Do not use a hammer.

7. Repeat steps 1-6 to attach the other wheel.

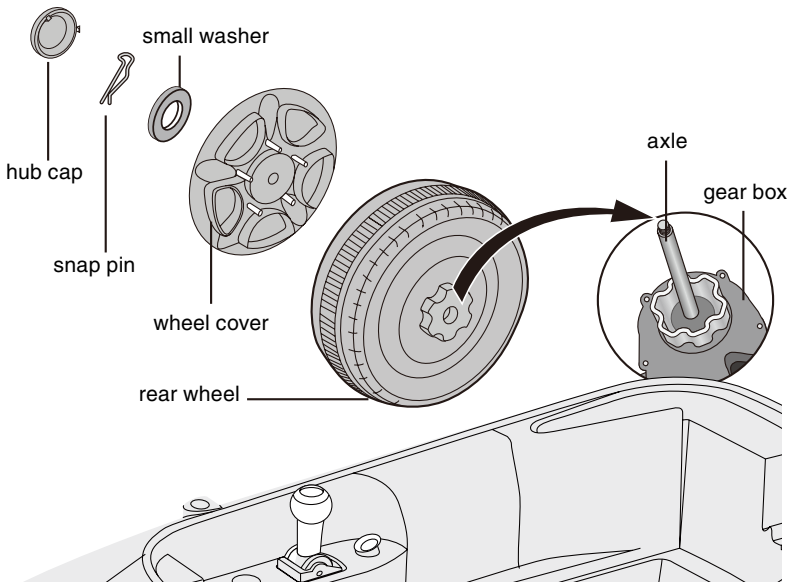

Attaching the Steering Wheel

1. Remove the battery compartment cover and insert (2) AA batteries into the top of the steering wheel. Place and screw the cover back on.
2. Place the steering wheel onto the steering column and line up the screw holes.
3. Insert the screw through the holes and thread the nut onto the screw.
4. Tighten the nut.

⚠ WARNING!

- DO NOT mix old and new batteries.
- DO NOT mix alkaline, standard (carbon-zinc), or rechargeable (nickel-cadmium) batteries.

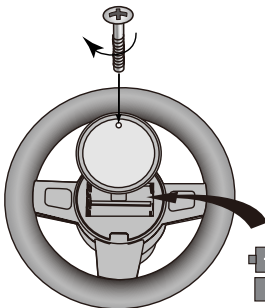
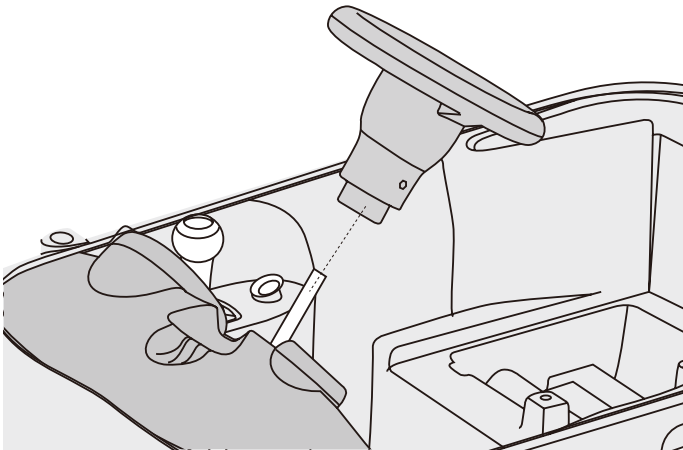

M5 x 42 screw

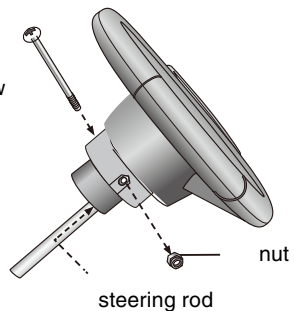

Assemble the Speedometer

Align the speedometer with the slot of the dashboard. Push it slightly until you hear the “click” to complete the assembly.

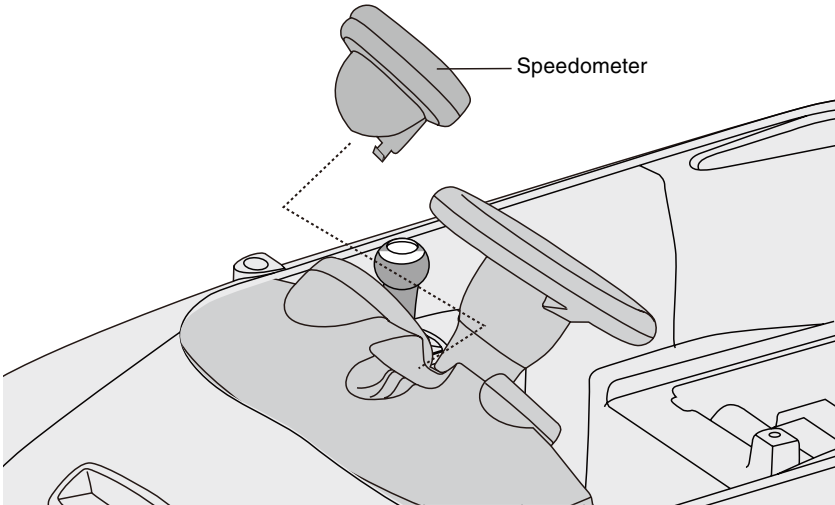

Assemble the Windshield

Align the windshield with the two side slots between the dashboard and the body and push it at the same time. NOTE: the two sides of the windshield must be inserted evenly. Push the middle of the windshield until you hear a “click”. The assembly is completed once you hear the “click.”

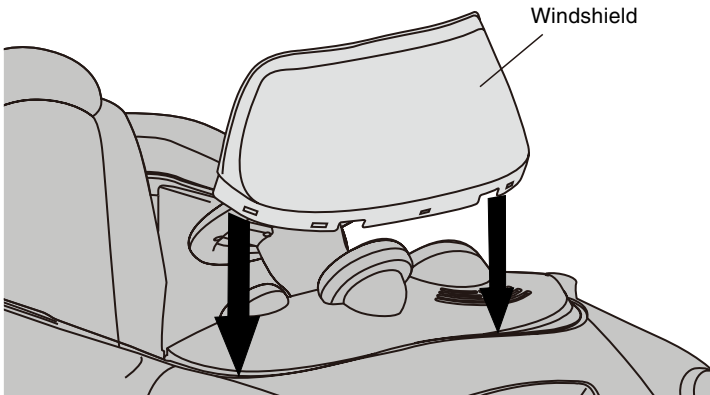

Assemble Soft Top

Align the clip of the soft top with the slot of the rear body, push it slightly until you hear a “click” to complete the assembly.

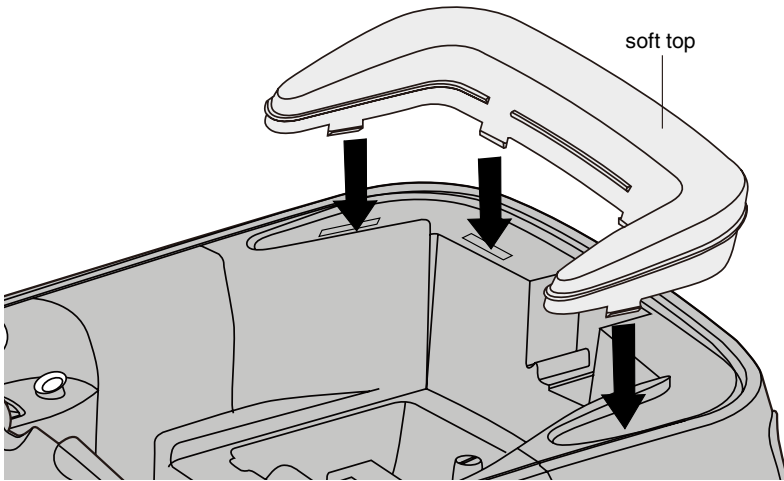

Assemble the Mirror

Insert the clip of the mirror into the slot of the body, push it into the slot until you hear a “click” to complete assembly. Please be reminded to differentiate the left and right mirrors.

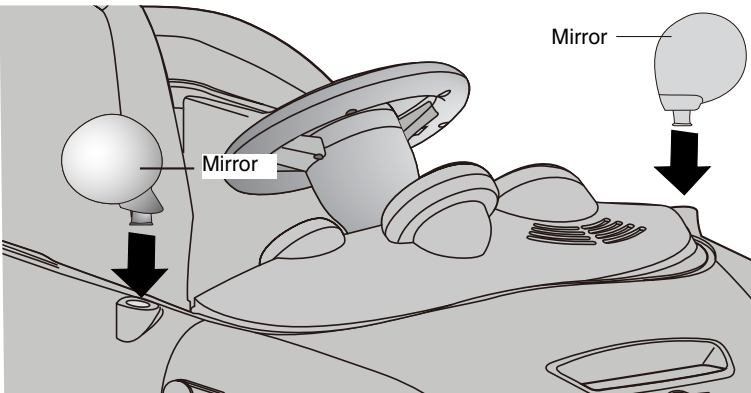

Attach the Remote Control batteries

Open the battery cover. Take out the old batteries and replace with new one. Then close the battery cover. Please change the battery following step above when the red light off on R/C found.

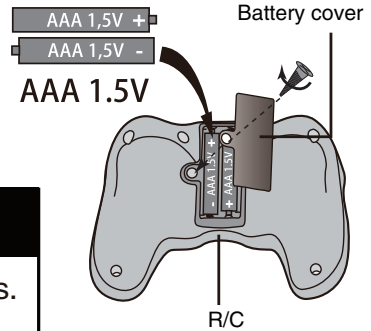

⚠ WARNING!

- DO NOT mix old and new batteries.
- DO NOT mix alkaline, standard (carbon-zinc), or rechargeable (nickel-cadmium) batteries.

Manual control operation

Seat in the car, turn the power switch to the position of "I", Press Remote/manual control switch to manual; Puush the forward/reverse shifter to forward or reverse position; press the foot pedal down to go forward on reverse release foot pedal to stop.

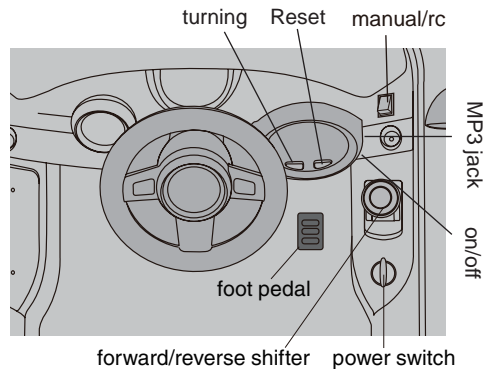

Turn on powder and radio switch, then can use chosen key to adjust different radio program, replacement key can make radio chosen to original position. MP3 line insert to the jack, then the radio will have different music as MP3 (volume can adjust by MP3).

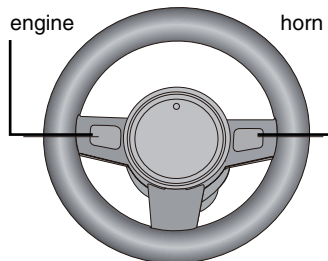

Engine sound on left and horn on right.

Remote Control Operation

Matching the code :

Press the match code button on the remote control until the LED is blinking, then release the code button and press only the match code button on the drive board until the Led stops blinking and keeps in light on status in just 1 seconds then it will be off, the recoding is Successful you can release your fingers.(If the LED keeps blinking over than 10 seconds , the recoding is fail and will at last be off automatically , the reason may be that there is no electricity on the drive board or the time interval between you press the button on the remote control and on the drive board is too long. To match the code again, please release the code buttons and repeat above steps.

If the recode is fail, please turn off the power and then turn on to recode. If it still couldn't work, please change a new remote –control and a new drive board.

Remote –control mode :

Rider sits in the car, turns on the power switch, set the manual / remote-control switch at remote-control mode. Move the lever on the 2.4G remote-control to forward or reverse position, the car will go forward or reverse accordingly, when move the lever to left or right position, the car will go to the left or right. The car will stop if the lever released. The headlightwill on when the car moves forward. There is no need to match the code when first using the remote-control. When it happens to replace the remote-control, motor control board or mal-function of the remote-control, please match the code again as Matching code steps.

Sleep mode:

If you don't operate the car in 8 hours after you turn on the power switch, the car will shift to sleep mode automatically. If you want to use the unit, please turn the power switch off and restart it to activate.

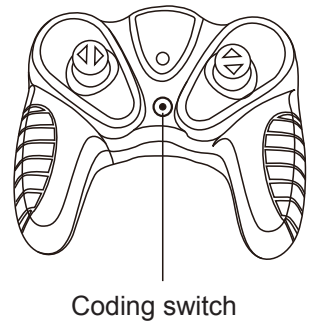
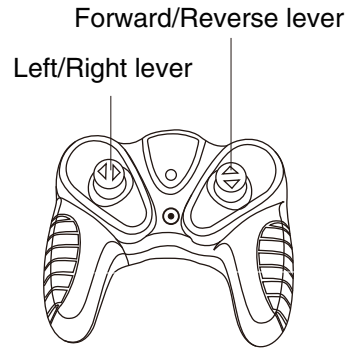

Coding switch

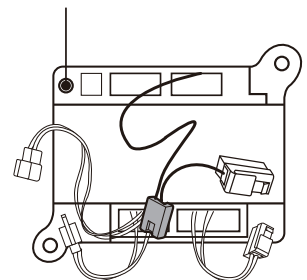

Maintenance

General

The vehicle should be checked for damage, missing or badly worn parts before use.

- Check the tightness of the fasteners before each use.
- Check the tightness of the wheel nuts. Use a flat head screw driver to gently pry off the hub caps. **Note:** If the screw nuts are not tight the wheels will not engage the forward gears and the vehicle will not run.
- Ensure the battery bracket is securely in place before use.
- Occasionally use lightweight oil to lubricate moving parts such as wheels and steering linkage. Do not use oil on plastic or nylon parts. No lubrication is required.
- Store the vehicle indoors or cover it with a tarp to protect it from the weather. Keep it away from sources of heat, such as stoves and heaters.
- Clean the vehicle with a soft, dry cloth. To restore shine to plastic parts, use a non-wax furniture polish. Do not use car wax, abrasive cleaners or wash the vehicle with soap and water. Water will damage the motor, electrical system and battery.

Battery

Only an adult who has read and understands the safety warnings (see Assembly) should handle, charge or recharge of the battery. Failure to comply with the following safety warnings may result in serious injury or death.

WARNING!

- DO NOT mix old and new batteries.
- DO NOT mix alkaline, standard (carbon-zinc), or rechargeable (nickel-cadmium) batteries.

⚠ WARNING!

The following safety hazards may result in serious injury or death to the user of the MINI Cooper S:



- Use of a battery or charger other than the supplied Avigo 6V rechargeable battery and charger may cause a fire or explosion. Only use the supplied 6V rechargeable battery and charger with the vehicle.
- Using the 6V rechargeable battery and charger for any other product may result in overheating, fire or explosion. Never use the 6V rechargeable battery and charger with another product.
- Explosive gases are created during charging. Charge the battery in a well ventilated area. Do not charge the battery near heat or flammable materials.
- Contact between the positive and negative terminals may result in fire or explosion. Avoid direct contact between the terminals. Picking up the battery by the wires or charger can cause damage to the battery and may result in a fire. Always pick up the battery by its case or handles.
- Liquids on the battery may cause fire or electric shock. Always keep all liquids away from the battery and keep the battery dry.



- Contact or exposure to battery leakage (lead acid) may cause serious injury. If contact or exposure occurs immediately call your physician. If the chemical is on the skin or in the eyes, with cool water for 15 minutes. If the chemical was swallowed, immediately give the person water or milk. Do not give water or milk if the patient is vomiting or has a decreased level of alertness. Do not induce vomiting.



WARNING!

The following safety hazards may result in serious injury or death to the user of the MINI Cooper S:

- Battery posts, terminals and related accessories contain **lead and lead compounds** (acid), chemicals that are toxic and corrosive. Never open the battery.



- Tampering or modifying the electric circuit system may cause a shock, fire or explosion and permanently damage the system. Exposed wiring, circuitry in the charger may cause electric shock. Always keep the charger housing closed.

Re-Charge Interval and Time

Important!

- Damage to the battery may occur if it is allowed to drain completely. Do not allow the battery to drain completely.
- Check the battery and charger (supply chord, connector) for wear and damage before charging. Do not charge the battery if damage has occurred. Only replace with a 6V rechargeable battery and charger.

The battery should be charged after each use, or if not used regularly, once a month at a minimum. Charge the battery for a full 16 hours. Do not charge the battery for more than 30 hours. Failure to charge the battery as directed would cause permanent damage to the battery and will void the warranty.

Battery Storage

Do not leave the battery connected in the vehicle for long period of times while not being used. This may drain the battery completely and cause permanent damage. Disconnect the battery connectors from the battery when the vehicle is not going to be used for a long period of time. Follow these guidelines if the battery is removed:

- Store the battery where temperatures are between -24°C and 24°C
- Store the battery on a wood surface. Do not place the battery on cement floor for extended periods. This will result in battery discharge.
- Wipe the battery clean with a dry cloth prior to storage.
- Charge the battery once every month for 16 hours.

Battery Replacement and Disposal

The Avigo 6V battery will eventually lose the ability to hold a charge. Depending on the amount of use, and varying conditions, the battery should operate for one to three years. Follow these steps to replace and dispose the battery:

1. Use a coin to loosen the 2 plastic screws in the seat. Lift the seat up and set aside.
2. Remove screws at bottom of the rear cover. Remove cover.
3. Disconnect the battery connectors.
4. Remove the battery bracket.
5. Carefully lift the battery.
 - Depending on the condition of the battery (i.e.:leakage) you may want to wear protective gloves before removal.
 - Do not lift the battery by its connectors or cables
6. Place the dead battery in a plastic bag.

Important! Recycle the dead battery responsibly. The battery contains lead acid (electrolyte) and must be disposed of properly and legally. It is illegal in most areas to incinerate lead acid batteries or dispose of them in landfills. Take it to a federal or state-approved lead acid battery recycler. Do not throw the battery away with your regular household trash!

7. Replace the battery with an 6V battery and reconnect the connectors.
8. Replace the metal battery bracket.
9. Replace the rear cover.
10. Replace the seat.

Battery Fuse

This toy features a thermal fuse with a reset fuse that will automatically trip and cut all power to the vehicle if the motor, electric system or battery is overloaded. The fuse will reset and power will be restored after the unit is turned **OFF** for 5 Minutes and then turned **ON** again. If the thermal fuse trips repeatedly during normal use, the vehicle may need repair.

To avoid losing power, follow these guidelines:

- Do not overload the vehicle
- Do not tow anything behind the vehicle
- Do not drive up steep slopes
- Do not drive into fixed objects, which may cause the wheels to spin, causing the motor to overheat.
- Do not drive in very hot weather; components may overheat.
- Do not allow water or other liquids to come in contact with the battery or other electric components.
- Do not tamper with the electric system. Doing so may create a short, causing the fuse to trip.

Troubleshooting Guide

The following are examples of potential problems. Completely read through this manual and the troubleshooting guide table before calling Hunter Products Service. If you still need help resolving the problem please contact Customer Service at www.electricrideon.com.au or call **1800224094**

| Problem | Possible Cause | Remedy |
|---|--------------------------------------|--|
| Vehicle does not run | Battery low on power | Recharge battery (see Battery: Recharge Interval and Time) |
| | Thermal fuse has tripped | Reset fuse (see Maintenance: General) |
| | Snap pins are loose | Tighten snap pins (see Maintenance: General) |
| | Battery connector or wires are loose | Check that the battery connectors are firmly plugged into each other. If wires are loose around the motor contact Customer Service |
| | Battery is dead | Replace battery (see Battery: Replacement and Disposal) |
| | Electrical system is damaged | Contact Customer Service |
| | Motor is damaged | Contact Customer Service |
| Vehicle does not run very long | Battery is under charged | Check that the battery connectors are plugged into each other when recharging (see Battery: Recharge Interval and Time) |
| | Battery is old | Replace battery (see Battery: Replacement and Disposal) |
| Vehicle runs sluggishly or beeping occurs | Battery low on power | Recharge battery (see Battery: Recharge Interval and Time) |
| | Battery is old | Recharge battery (see Battery: Recharge Interval and Time) |

| Problem | Possible Cause | Remedy |
|--|--|--|
| Vehicle runs sluggishly or beeping occurs | Vehicle is overloaded | Reduce weight on vehicle (see User Requirements and Safety Warnings) |
| | Vehicle is being used in harsh conditions | Operate the vehicle level ground and firm surfaces (see User Requirements and Safety Warnings) |
| Vehicle needs a push to go forward | Poor contact of wires or connectors | Check that battery connectors are firmly plugged into each other. If wires are loose around the motor contact Customer Service |
| | “Dead Spot” on motor | A dead spot means the electric power is not being delivered to the terminal connection and the vehicle needs repair. Contact Customer Service |
| Difficult shifting from forward to reverse or visa-versa | Attempting to shift while the vehicle is in motion | Completely stop the vehicle and shift (see Use: Manual Operation) |
| Loud grinding or clicking noises coming from motor or gear box | Motor or gears are damaged | Contact Customer Service for an authorised service center |
| 6V Battery will not recharge | Battery connector or adapter connector is loose | Check that battery connectors are firmly plugged into each other |
| | Charger not plugged in | Check that battery charger is plugged into a working wall outlet |
| | Charger is not working (lights not glowing) | Contact Customer Service |
| Battery bubbles or gurgles when charging | This is normal and not a cause for concern | |
| Charger feels warm when recharging | This is normal and not a cause for concern | |

Services, Repairs and Parts

If your MINI Cooper S needs service, repairs or replacement parts, call:

Hunter Products Pty Ltd

Hours: 8:30am – 4:30pm (AEST) Monday - Friday

Service Phone: 1800224094

Web: www.electricrideon.com.au

Warranty

One-Year Limited Warranty

Hunter Products warrants that your MINI COOPER S 6v will be free from defects in materials and workmanship for the vehicle (except for the 6-volt battery) for a period of 12 months, from the date of purchase. This warranty only applies where the product is completely and correctly assembled and used in accordance with all accompanying recommendations and users instructions. This warranty is in addition to your rights under the Australia Consumer Law.

Hunter Products, at its option will provide you with a refund or replacement parts for this product if the MINI COOPER S 6v becomes defective within the warranty period. Hunter Products will bear the reasonable expense of claiming the warranty. This warranty will no longer apply where the defect is a result of an accident, misuse, abuse, neglect or other causes not arising out of defects in materials or workmanship, nor does it cover damages arising out of damages arising out of service by other than an authorised service person.

Our goods come with guarantees that cannot be excluded under the Australian Consumer Law. You are entitled to a replacement or refund for a major failure and compensation for any other reasonably foreseeable loss or damage. You are also entitled to have the goods repaired or replaced if the goods fail to be of acceptable quality and the failure does not amount to a major failure.

Please retain your receipt as proof of purchase and contact Hunter Products for further assistance on how to process any warranty claims.

Business name: Hunter Products Pty Ltd
Business address: Level 2, 424 Warrigal Road, Moorabbin VIC 3189, Australia
Telephone number: Australia wide (local call cost) 1800224094
(Monday to Friday 8.30 to 4.30pm AEST)
Email address: www.electricrideon.com.au

Contact Information

If you have any questions or comments please contact us at:

Hunter Products Pty Ltd
Level 2, 424 Warrigal Road
Moorabbin VIC 3189, Australia
Web: www.electricrideon.com.au
Phone: 1800224094 (local call cost)