

ATTENTION!

For Any Issues with this Product, Contact Customer Service.

We are glad to assist you with any parts or assembly problems you might have!

[AUSTRALIA]

For Any Issues with this Product, Contact Customer Service.

Hunter Products Pty Ltd

233 Bay Street, Brighton Victoria, 3186,
Australia

Phone: 1800 224 094

Email: enquiries@hunterproducts.com.au

ALWAYS WEAR YOUR HELMET WHEN RIDING THIS PRODUCT!

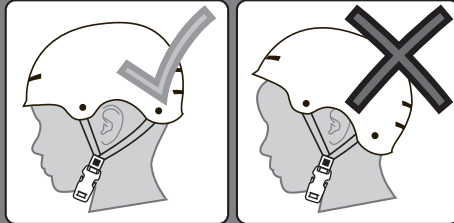

Always read the user manual that comes with your helmet to make sure it is fitted and attached properly to the wearer's head according to the fitting instructions described in the user manual.

<https://www.huffybikes.com/global-contacts/>
for current global contact information



For ASSEMBLY Help:
Aide à l'ASSEMBLAGE :
Ayuda de la ASAMBLEA:

<https://www.huffybikes.com/global-contacts/>

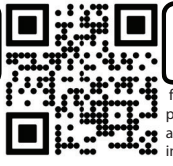

Please REGISTER your Product:
Veuillez ENREGISTRER l'article :
Por favor, REGISTRE su producto:

for current contact information /
pour les informations de contact
actuelles / para obtener la
información de contacto actual



H-ERO-PP-Quad AU 10-12-21 m0899



Date Code Label
Here

Owner's Manual for Battery Ride On

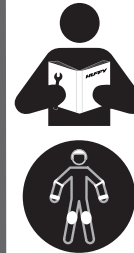

This manual contains important safety, assembly, operation and maintenance information.

Please read and fully understand this manual before operation.

Save this manual for future reference.



Always wear approved helmet and safety equipment when using this product.



© Copyright Huffy Corporation 2021

See back page for Customer Service Information

Owner's Manual Index

Safety and Warnings	2-6
Parts List and Product Assembly	7-13
Operation and Charging Battery	13-14
Maintenance Repair and Service	15-17
• General Info, Battery Storage, Replacement and Disposal	
Troubleshooting	18
Warranty	19
Back Cover:	
• Return and Service Contact information	
• Registration QR Code Link	
• Assembly QR Code Link	

⚠ WARNING - TO AVOID SERIOUS INJURY:

- The user must be **1.5-3 years**
- Not for children with a body mass of more than **45 lb (20 kg)**
- Never allow more than **1** rider

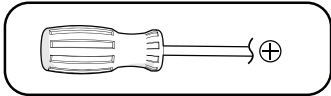

Tools Needed

IMPORTANT! Before using the unit for the first time the battery needs to be charged for at least **8 to 12** hours - no more than **20** hours. Only an adult who has read and understands the safety warnings should handle, charge or recharge of the battery (see **Operation** section). **NOTE:** It is not necessary to remove the battery from the vehicle for charging.

This product meets ASTM F963 and CPSIA requirements for electric vehicles.

Limited Warranty (Australia)

General:

Part or model specifications are subject to change without notice.

This Limited Warranty is the only warranty for the product. ALL WARRANTIES OTHER THAN STATED HEREIN ARE DISCLAIMED INCLUDING IMPLIED WARRANTIES OF MERCHANTABILITY AND FITNESS FOR A PARTICULAR PURPOSE, TO THE EXTENT ALLOWABLE BY APPLICABLE LAW. ALL LIABILITY FOR INCIDENTAL, PUNITIVE, SPECIAL, OR CONSEQUENTIAL DAMAGES ARE EXPRESSLY DISCLAIMED, TO THE EXTENT ALLOWABLE BY APPLICABLE LAW.

The only uses for this product are described in this manual.

Warranty registration is not required.

The Limited Warranty extends only to the original consumer and is not transferable to anyone else.

What does this Limited Warranty cover?

This Limited Warranty covers defects in workmanship and materials for all parts of the product except those indicated below as not warranted.

What must you do to keep the Limited Warranty in effect?

This Limited Warranty is effective only if:

- Product is completely and correctly assembled.
- Product is used under normal conditions for its intended purpose (see the following section for excluded activities).
- Product receives all necessary maintenance and adjustments.
- Product is used for general transportation and recreational use only.

What is not covered by this Limited Warranty?

This product is designed for recreational use only. This Limited Warranty does not cover normal wear and tear, normal maintenance items, or any damage, failure, or loss that is caused by improper assembly, maintenance, adjustment, storage, or use of the product. This Limited Warranty does not extend to future performance.

This Limited Warranty will be void if the product is ever:

- Used in any competitive sport
- Used for stunt riding, jumping, aerobatics or similar activity
- Modified in any way
- Modified with the addition of a motor

- Ridden by more than one person at a time
- Rented, sold, or given away
- Used in a manner contrary to the instructions and warnings in this Owner's Manual

What will The Manufacturer do?

Manufacturer's sole and exclusive obligation under this Limited Warranty is to repair and/or replace, at its sole option, any covered defect in workmanship or materials.

How do you report a problem with this product or submit a warranty claim?

- Contact Customer Service in Australia or New Zealand (See included list for Customer Contact information).
- Warranty claims can be submitted to; Hunter Products Pty Ltd - PH: 1800 224 094 Email: enquiries@hunterproducts.com.au - Level 2, 424 Warrigal Road, Moorabbin, Victoria 3189 Australia.

The following text is incorporated into this Limited Warranty if this product was purchased in Australia (but it is not incorporated if such product was purchased in New Zealand):

- Our goods come with guarantees that cannot be excluded under the Australian Consumer Law. You are entitled to a replacement or refund for a major failure and for compensation for any other reasonably foreseeable loss or damage. You are also entitled to have the goods repaired or replaced if the goods fail to be of acceptable quality and the failure does not amount to a major failure.

What rights do you have?

This Limited Warranty gives you specific legal rights. You may also have other rights which vary from State to State.

For how long does this Limited Warranty last?

- When used in this Limited Warranty, the phrase "for life" means for as long as the original consumer owns the product.
- Drive Battery - 90 days
- Electronics - 90 days
- All other Components - 6 months

Troubleshooting Guide

The following are examples of potential problems. Completely read through this manual and the troubleshooting guide table before calling. If you still need help resolving the problem please contact Customer Service.

NOTE: Vehicle should be turned off and fully charged before doing troubleshooting.

Problem	Possible Cause	Solution
Vehicle does not run when switch is activated	Battery wires not connected or are loose	Connect battery wires according to assembly instructions, Check that the battery connectors are firmly plugged into each other. If wires are loose around the motor call Customer Service.
	Battery low on power	Recharge battery (see Battery: Recharge interval and time)
	Battery Charger still plugged in	Unplug Battery Charger from unit and wall in
	Thermal fuse has tripped	Let Fuse reset
	Battery is dead	Replace battery (see Battery: Replacement and Disposal)
	Electrical system or motor is damaged	Call Customer Service.
Vehicle does not run very long or runs sluggishly	Battery is undercharged.	Check that the battery connectors are firmly plugged into each other when recharging (see Battery: Recharge interval and Time)
	Battery is old and cannot be fully charged	Replace battery (see Battery: Replacement and Disposal)
	Vehicle is overloaded	Reduce weight on vehicle (see user requirements and Safety Warnings)
	Vehicle is being used in harsh conditions	Avoid using vehicle in harsh conditions (see User Requirements and Safety Warnings)
Vehicle makes loud noise when in use	Chain is dry (on chain drive models)	Lubricate chain with light oil.
Loud grinding or clicking noises coming from motor or gear box	Motor or gears are damaged	Call Customer Service.
	Drive Wheel is partially engaged	Check drive wheel - to motor engagement.
Battery will not recharge	Battery connector or adapter connector is loose	Check that the battery connectors are firmly plugged into each other.
	Charger is not working	Check that the battery charger is plugged into a working wall outlet.
	Battery is dead	Replace battery.
Charger feels warm when recharging	This is normal and not a cause for concern	If excessively hot, unplug and replace.



WARNING - TO AVOID SERIOUS INJURY:

Here are basic, common sense safe riding practices you should read aloud to your child and anyone who may use the vehicle.

It is the responsibility of the adult to educate the child, determine if they are fit to operate the vehicle, and supervise use.

To avoid serious injury or death follow these safety rules and guidelines:

- **Adult assembly required.** Choking hazard to children under the age of 3 years - contains small parts. Keep small children away when assembling. Keep poly bags away from child.
- After complete assembly, remove and dispose of all protective material and poly bags. Be sure to remove all packaging materials and parts from underneath the vehicle body.
- To reduce the risk of injury, **continuous adult supervision is required** while using the vehicle.
- It is the responsibility of the adult to educate the child and determine if they are capable of operating the vehicle safely.
- Ensure child uses common sense and safe practices when using the vehicle.
- Before using the vehicle the child must understand the controls and safety issues. They must also demonstrate the capability and skill to handle the vehicle and operate its controls to avoid falls or collisions.
- **Protective Equipment must be worn:** Always wear safety equipment such as a helmet that meets CPSC (or equivalent standard for your country) with chinstrap securely fastened, knee pads, elbow pads, wrist guards, gloves and shoes.
- If equipped, child should always use properly and securely attached Seat Belt.
- **SEATED MODELS:** Always sit in the seat when using the vehicle. Do not stand on side boards. Do not stand on or in vehicle while moving.
- **FOOT/FENDER BRAKE MODELS:** Fender can become hot after use. Do Not touch with hand.
- **MODELS WITH NO BRAKES:** Motor friction will gradually stop the unit.
- Self-locking nuts and other self-locking fixings may lose their effectiveness when reused.
- Body parts such as hands, legs, hair and clothing can get caught in moving parts. Never place a body part near a moving part or wear loose clothing while using the vehicle.
- **Do not use the vehicle in an unsafe manner or at an unsafe speed. Examples include but are not limited to:**
 - Always use vehicle in a safe, secure environment on flat, smooth paved surfaces only.
 - Never use in roadways, near motor vehicles, on or near steep inclines or steps, swimming pools or other bodies of water.
 - Do not pull or push the vehicle with another vehicle or similar device.
 - Do not tow anything behind the vehicle.
 - Do not drive into fixed objects, which may cause the wheels to spin, causing the motor to overheat.
 - Never use near streets, water, swimming pools, hills, steps, drop-offs, sloped surfaces or driveways, wet areas, flammable vapors, in alleys, at night or in the dark.
 - Do not use the vehicle in unsafe conditions such as snow, rain, loose dirt, mud sand or fine gravel. This may result in unexpected action such as tip over and skidding. Using the

! WARNING - TO AVOID SERIOUS INJURY:

- vehicle in loose dirt, mud, sand, or fine gravel may damage the electronics and gear box inside the vehicle.
- Do not overload the vehicle. Do not drive in very hot weather, components may overheat. Do not allow water or other liquids to come in contact with the battery or other electric components.
- Obey all local traffic and scooter riding laws and regulations.
- Do not tamper with the electrical system. Doing so may create a short, causing the fuse to trip or other damage including fire.
- RISK OF FIRE.** Do not bypass fuse. Replace only with original size and type.
- There are additional hazards of using the vehicle in areas other than private grounds.
- Only use authorised replacement parts.
- Before each ride, check that the steering system is correctly adjusted and that all connection components are firmly secured and not broken
- Refer to the Assembly Manual for the correct techniques for use and for braking
- While using the product, keep hands and fingers away from wheels and other moving parts to avoid danger of pinching or entrapment.
- If wheels or bearings are worn and do not spin freely, replace with original equipment.
- Non-rechargeable batteries are not to be recharged
- Batteries are to be inserted with the correct polarity
- The supply terminals are not to be short-circuited
- Rechargeable battery is only to be charged by adults
- The battery chargers used with the toy are to be regularly examined for damage to the cord, plug, enclosure and other parts, and in the event of such damage, they must not be used until the damage has been repaired.

ALWAYS WEAR YOUR HELMET WHEN RIDING THIS PRODUCT!

Always read the user manual that comes with your helmet to make sure it is fitted and attached properly to the wearer's head according to the fitting instructions described in the user manual.

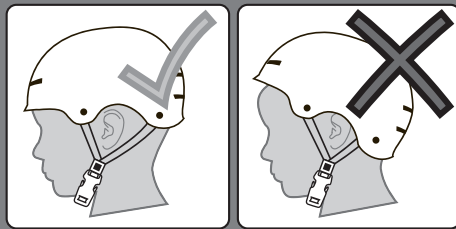
**Drive Motor Battery**

Only an adult who has read and understands the safety warnings should handle, charge or recharge the battery. Failure to comply with all safety warnings may result in serious injury or death.

Battery Fuse

The drive motor circuit features a thermal fuse that will automatically trip and cut all power to the vehicle if the motor, electric system or battery is overloaded. The fuse will reset and power will be restored after a short time. If the thermal fuse trips repeatedly during normal use, the vehicle may need repair.

! WARNING: DO NOT BYPASS THE FUSE - RISK OF FIRE. This may overload and damage the electrical system.

Battery Re-charge Interval and Time**IMPORTANT!**

Check the drive battery and charger (supply cord, connector) for wear and damage before charging. Do not charge the battery if damage has occurred. Only replace with the same type and voltage rechargeable battery and charger supplied by the manufacturer.

- Only use the rechargeable battery (or equivalent replacement) and charger supplied with your vehicle.
- Before first use, charge battery **8 to 12 hours - never longer than 20 hours.**
- Once battery is depleted, recharge for **8 to 12 hours - never longer than 20 hours.**
- Do not short circuit the battery: Do NOT connect red and black wires together or connect positive and negative terminals on the battery together.
- When battery is fully charged, un-plug charger from the wall outlet and disconnect from charger port.

The drive battery should be charged when depleted, or if not used regularly, once a month. Failure to charge the battery as directed will cause permanent damage to the battery and will void the warranty.

Drive Battery Replacement

FOLLOW THESE STEPS IF THE BATTERY NEEDS TO BE REPLACED:

NOTE: Batteries are installed, mounted and wired differently depending on model. **Make a simple drawing on paper** (or take pictures) how your battery is installed and how Red and Black wires are connected.

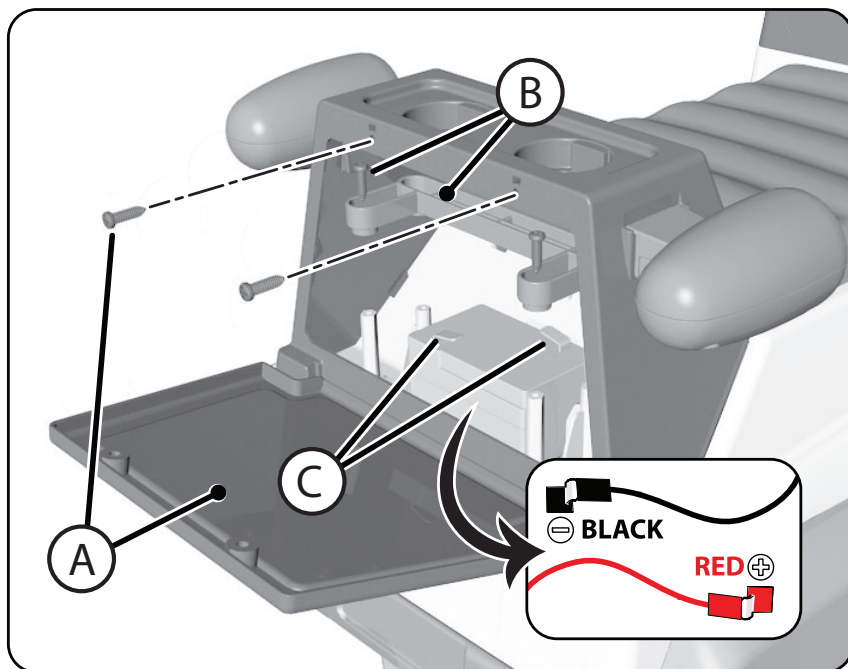

1. Remove Screws and open Battery Compartment (A).
2. Remove Screws and Hold-Down Bracket (B).
3. Carefully remove wires from Terminals (C).
4. Carefully lift out the Battery.
 - Depending on the condition of the battery (i.e.: leakage) you may want to wear protective rubber gloves before removal.
 - Do not lift the battery by its connectors or cables.
5. Place the dead battery in a plastic bag.
6. Install replacement battery in same position and orientation as original.
7. Re-connect all wires (C) **in original positions - RED to RED, BLACK to BLACK.**
8. Re-install Battery Hold-down Bracket and Screws (B).

⚠ WARNING: Ensure no wires are pinched or bound up.

9. Close Battery Compartment Cover and install Screws (A).

⚠ BATTERY & CHARGER WARNINGS: AU



The following safety hazards may result in serious injury or death to the user of the vehicle:

- The charger is not to be used by persons (including children) with reduced physical, sensory or mental capabilities, or lack of experience and knowledge, unless they have been given supervision or instruction.
- Battery Charger is NOT to be used by Children.
- Rechargeable battery is only to be charged by adults.
- Battery Charger for Indoor use only.
- Use of a battery or charger other than the supplied rechargeable battery and charger may cause a fire or explosion. Only use the supplied rechargeable battery (or lead-acid or lithium suitable replacement) and charger with the vehicle.
- Using the rechargeable battery and charger for any other product may result in overheating, fire or explosion. Never use the rechargeable battery and charger with another product.
- Explosive gases are created during charging. Charge the battery in a well ventilated area. Do not charge the battery near heat or flammable materials.
- Contact between the positive and negative terminals may result in fire or explosion. Avoid direct contact between the terminals. Picking up the battery by the wires or charger can cause damage to the battery and may result in a fire. Always pick up the battery by its case or handles.
- Battery must be handled by adults only. Liquids on the battery may cause fire or electric shock. Always keep all liquids away from the battery and keep the battery dry.
 - Contact or exposure to battery leakage (lead acid) may cause serious injury. If contact or exposure occurs immediately call your physician. If the chemical is on the skin or in the eyes, flush with cool water for 15 minutes. If the chemical was swallowed, immediately give the person water or milk if the patient is vomiting or has a decreased level of alertness. Do not induce vomiting.
- Battery Posts, terminals and related accessories contain lead and lead compounds (acid), chemicals known to cause cancer, reproductive harm and are toxic and corrosive. Never open the battery.
- Tampering or modifying the electric circuit system may cause a shock, fire or explosion and permanently damage the system. Exposed wiring and circuitry in the charger may cause electric shock. Always keep the charger housing closed.
- Non-rechargeable batteries are not to be recharged
- Batteries are to be inserted with the correct polarity
- The supply terminals are not to be short-circuited
- The battery chargers used with the toy are to be regularly examined for damage to the cord, plug, enclosure and other parts, and in the event of such damage, they must not be used until the damage has been repaired.
- Do not mix old and new batteries.
- Do not mix alkaline, standard (Carbon-Zinc) or rechargeable batteries.
- Non-Drive rechargeable batteries are to be removed from the unit before being charged.

Radio Frequency Information (if applicable)

CAUTION: Changes or modifications to this unit not expressly approved by the party responsible for compliance could void the user's authority to operate the equipment. This device complies with Part 15 of the FCC Rules. Operation is subject to the following two conditions:

(1) this device may not cause harmful interference, and (2) this device must accept any interference received, including interference that may cause undesired operation.

NOTE: This equipment has been tested and found to comply with the limits for a Class B digital device, pursuant to Part 15 of the FCC Rules. These limits are designed to provide reasonable protection against harmful interference in a residential installation. This equipment generates, uses and can radiate radio frequency energy and, if not installed and used in accordance with the instructions,

may cause harmful interference to radio communications.

However, there is no guarantee that interference will not occur in a particular installation. If this equipment does cause harmful interference to radio or television reception, which can be determined by turning the equipment off and on, the user is encouraged to try to correct the interference by one or more of the following measures:

- Reorient or relocate the receiving antenna.
- Increase the separation between the equipment and receiver.
- Connect the equipment into an outlet on a circuit different from that to which the receiver is connected.
- Consult the dealer or an experienced radio/TV technician for help.

Maintenance Repair and Service

GENERAL: The vehicle should be checked for damage, missing or badly worn parts before each use. If any part of the product does not operate properly – discontinue use.

- Check the tightness of the fasteners before each use. Replace any fasteners that are damaged.
- Inspect the product frequently. Failure to inspect the product and to make repairs or adjustments, as necessary, can result in injury to the rider or to others. Make sure all parts are correctly assembled and adjusted as written in this manual and any "Special Instructions".
- Immediately replace any damaged, missing, or badly worn parts.
- Make sure all fasteners are correctly tightened as written in this manual and any "Special Instructions". Parts that are not tight enough can be lost or operate poorly. Over tightened parts can be damaged. Make sure any replacement fasteners are the correct size and type.

- Check the tightness of the wheels:
- NOTE:** If the drive wheel is not tight, it will not engage the gears and the vehicle will not run.
- Ensure the battery bracket is securely in place before use.
 - Store the vehicle indoors. Keep it away from sources of heat, such as stoves and heaters.
 - Keep the product clean and free of dirt, dust and water. This will prolong the useful life of the product.
 - Clean the vehicle with a soft, dry cloth. To restore shine to plastic parts, use a non-wax furniture polish. Do not use automotive wax, abrasive cleaners or wash the vehicle with soap and water.
- NOTE:** If the instructions in this manual or any "Special Instructions" are not sufficient for you, please contact customer service.
- CAUTION:** Self-locking nuts and other self-locking devices may lose their effectiveness when re-used.

Battery Storage and Disposal

The drive battery should be charged when depleted, or if not used regularly, once a month. Failure to charge the battery as directed will cause permanent damage to the battery and will void the warranty.

Follow these guidelines if the battery is removed:

- Do not store battery in extreme hot or cold temperatures.
- Wipe the battery clean with a dry cloth prior to storage. Wash cloth separate from other clothes.

BATTERY DISPOSAL:

- The sealed lead-acid battery must be re-

cycled or disposed of in an environmentally sound manner.

- Do not dispose of battery in a fire. The battery may explode or leak acid.
- Do not dispose of the battery in household trash. The incineration, land filling or mixing of sealed lead-acid batteries with household trash is prohibited by law.
- Return an exhausted battery to a federal or state approved lead-acid battery recycler, such as a local seller of automotive batteries (check local battery disposal regulations).

Charging the Drive Battery:



IMPORTANT! Before using the unit for the first time the battery needs to be charged for at least **8 to 12 hours** - no more than **20 hours**. Once battery is depleted, recharge for **8 to 12 hours** - no more than **20 hours**.

IMPORTANT!

Check the drive battery and charger (supply cord, connector) for wear and damage before charging. Do not charge the battery if damage has occurred. Only replace with the same type and voltage rechargeable battery and charger supplied by the manufacturer.

- Only use the rechargeable battery (or equivalent replacement) and charger supplied with your vehicle.
- Always turn power off and charge battery after riding.
- The drive battery should be charged when depleted, or if not used regularly, once a month. Failure to charge the battery as directed will cause permanent damage to the battery and will void the warranty.

STEPS:

1. Ensure power is OFF.
2. Locate Charging Port **(A)**.
3. Plug Charger plug into unit Charging Port.
4. Plug Charger into Wall outlet **(B)**.
5. When battery is fully charged, unplug charger from the wall outlet and disconnect from charger port.

NOTE: The charger may feel warm during the charging. If excessively hot, unplug and replace.

NOTE: This product has charging protection: When charging, drive functions are turned OFF.

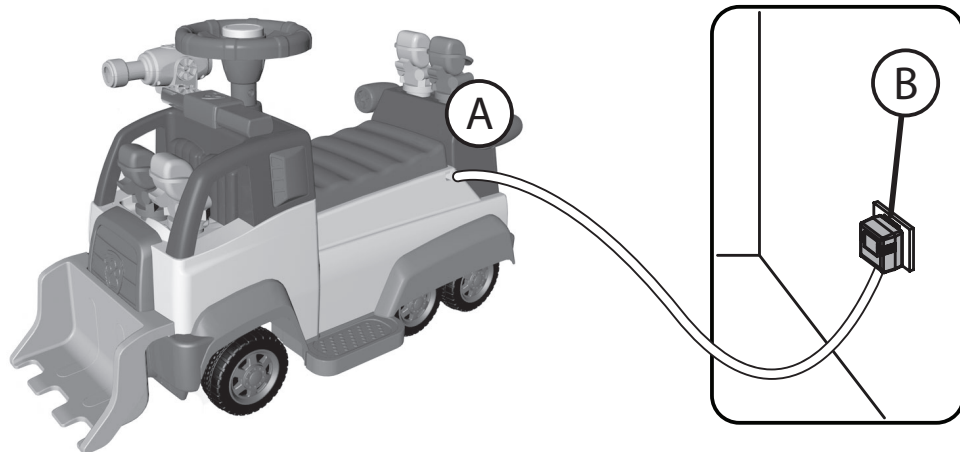

Introduction to Assembly

This Owner's Manual may be made for several different style products.

- Some illustrations may vary slightly from the actual product.
- Follow instructions completely.
- If the product has any parts that are not described in this manual, look for separate "Special Instructions" that are supplied with the unit.
- All features, components and accessories are not included on all models.
- Use the Index page to locate specific sections of this manual.
- Please read through this entire manual before beginning assembly or maintenance.
- If you are not confident with assembling this unit, contact customer service.

! WARNING: Keep small parts away from children during assembly.

NOTE: All of the directions (right, left, front, rear, etc.) in this manual are as seen by the rider while seated.

Do not dispose of the carton and packaging until you complete the assembly of the product. This can prevent accidentally discarding parts of the unit.

NOTE: SOME PARTS MAY BE STORED UNDER SEAT.

TO REMOVE SEAT:

1. Grasp rear sides of Seat and pull UP until back of Seat comes loose.
2. Lift Seat up and off.

TO INSTALL SEAT:

3. Tilt front of Seat down as shown.
4. Position Seat so Front Tabs **(A)** align with Slots.
5. Push down back of Seat so Rear Tab **(B)** SNAPS into place in Rear Slot.

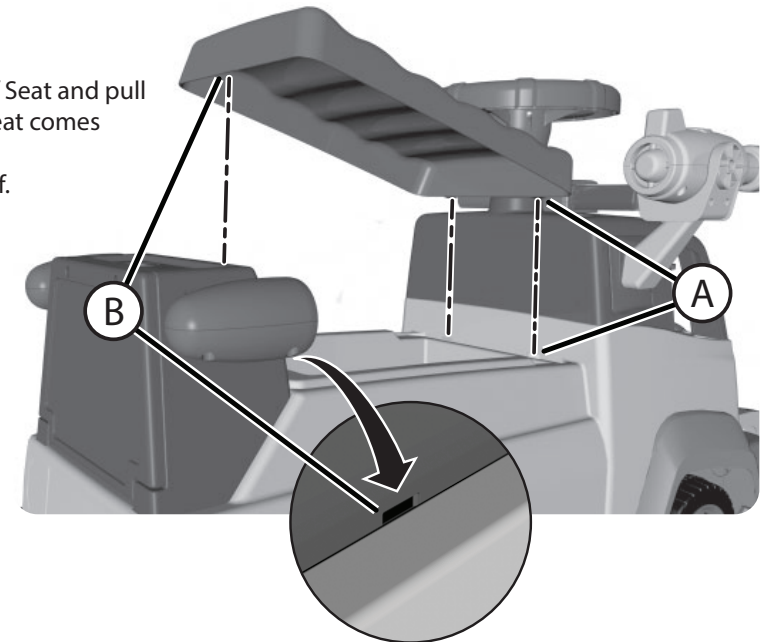

Parts Assembly

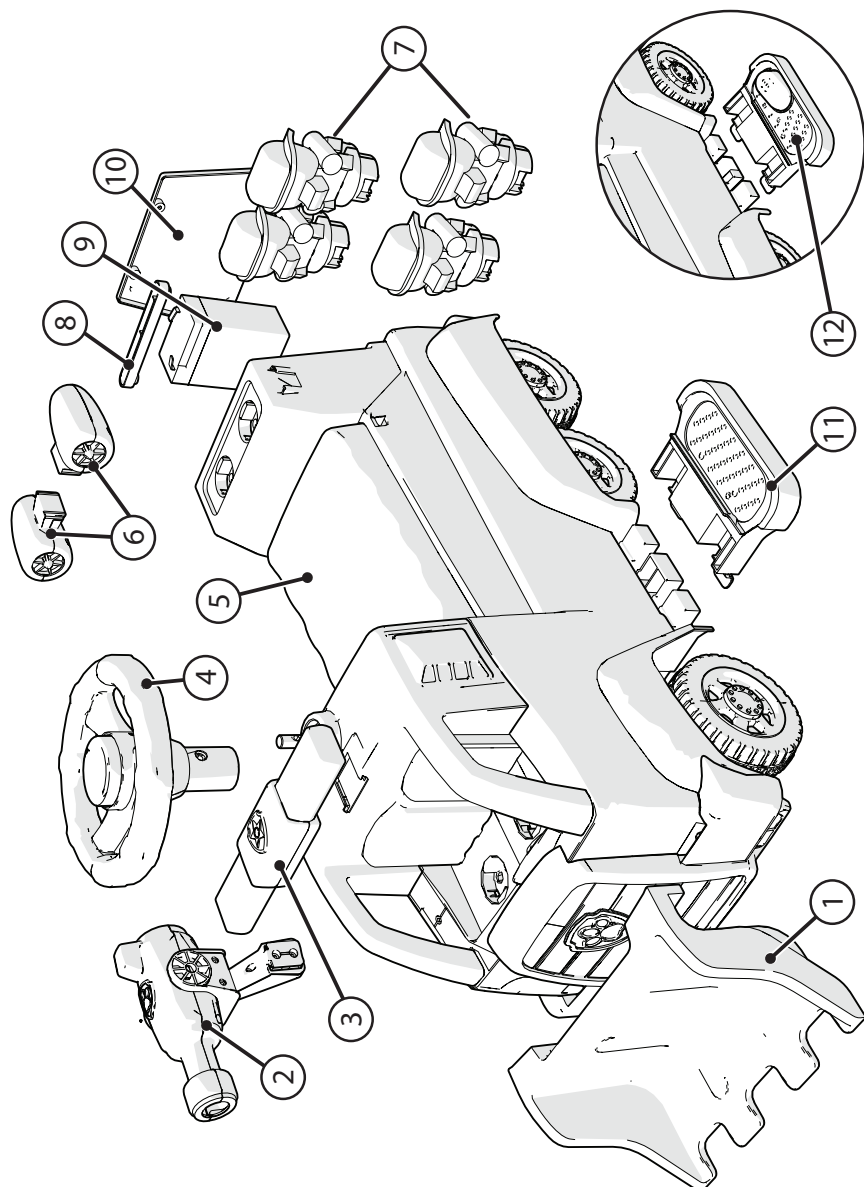

Assembly / Operation

OPERATION: HOW-TO:

- Press Power Switch (A) to turn unit on.
- Press Foot Switch (B) to move forward.
- Release Foot Switch (B) and unit will gradually stop using motor friction.

! **WARNING:**

- Read and understand ALL warnings about riding this product in the front of this manual!

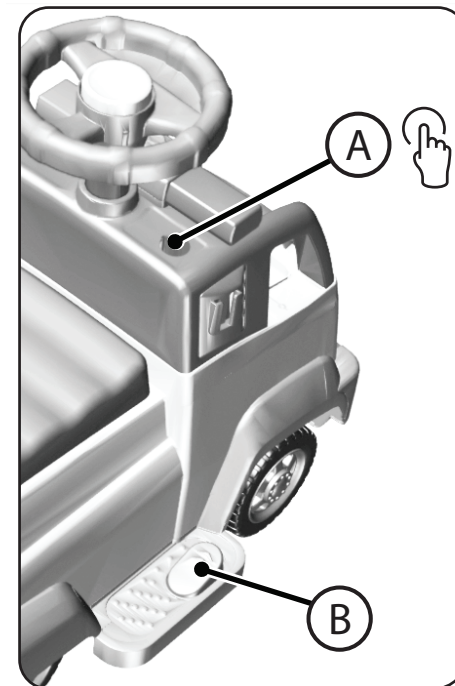

Assembly

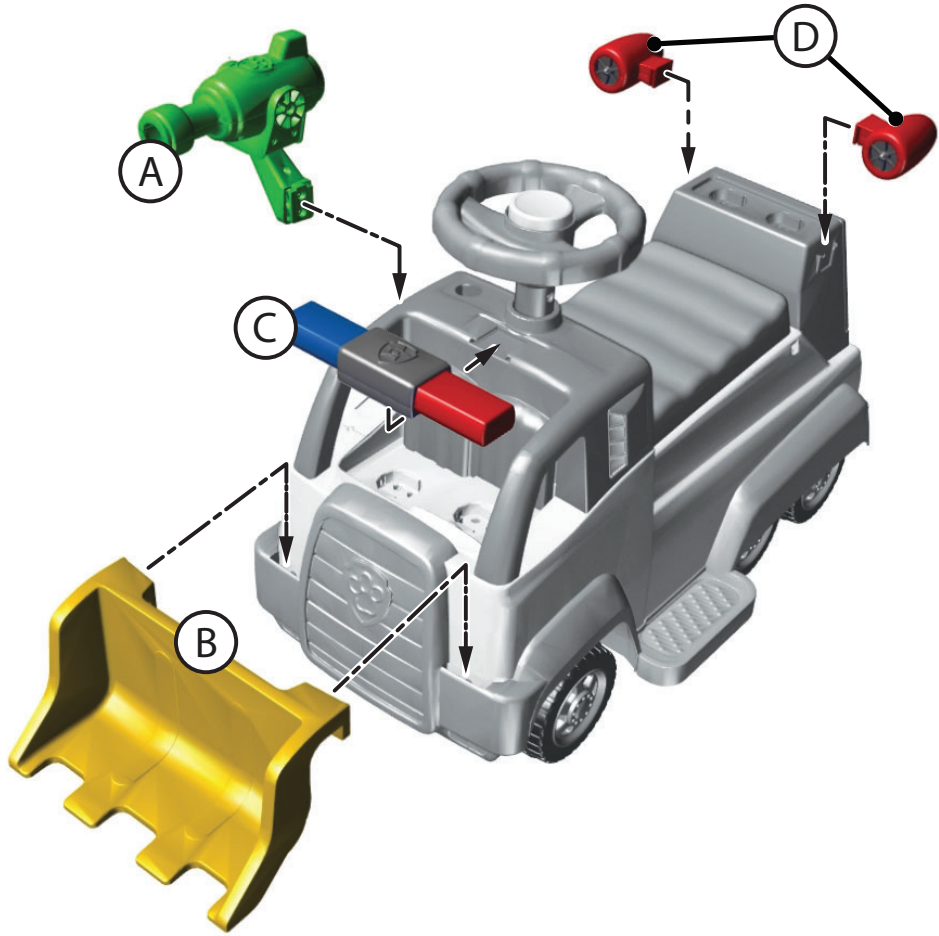

HOW-TO:

- **Attach Accessories by sliding them into place as shown.**
 - Water Cannon: (A)
 - Front Scoop/Shovel: (B)
 - Light Bar: (C)
 - Engines: (D)

Parts Assembly

#	Description	#	Description
1	Front Shovel/Scoop	7	Figure Set (x4)
2	Water Cannon	8	Battery Clamp and hardware
3	Light Bar	9	Battery
4	Steering Wheel	10	Battery Door
5	Seat Storage/cover	11	Foot Rest (left)
6	Engines (x2)	12	Foot Rest - Power Switch (right)

Assembly

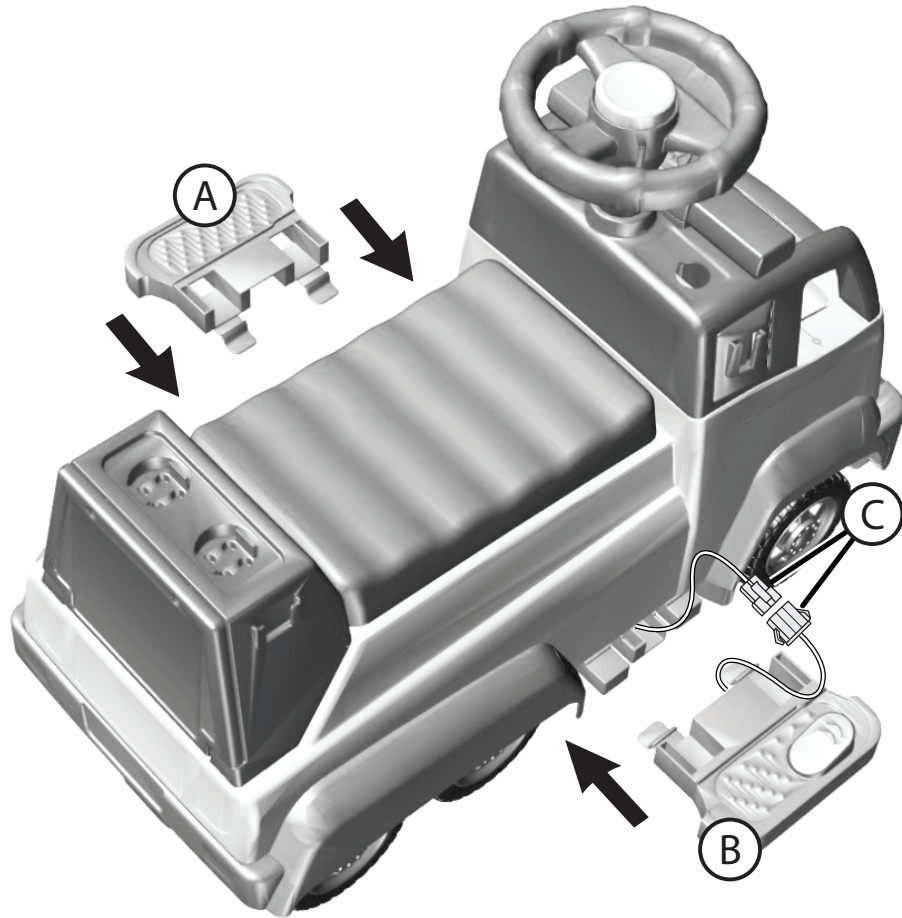

STEPS:

1. Position Left Footrest (A) as shown and SNAP firmly and completely into car body. Gently pull out to ensure it does not come loose.
2. Position Right Footrest (B) as shown and firmly connect Power Connector (C). Put extra wires inside body channel.
1. SNAP Right Footrest (B) firmly and completely into car body. Gently pull out to ensure it does not come loose.

⚠ WARNING: Ensure no wires are pinched or bound up.

Assembly

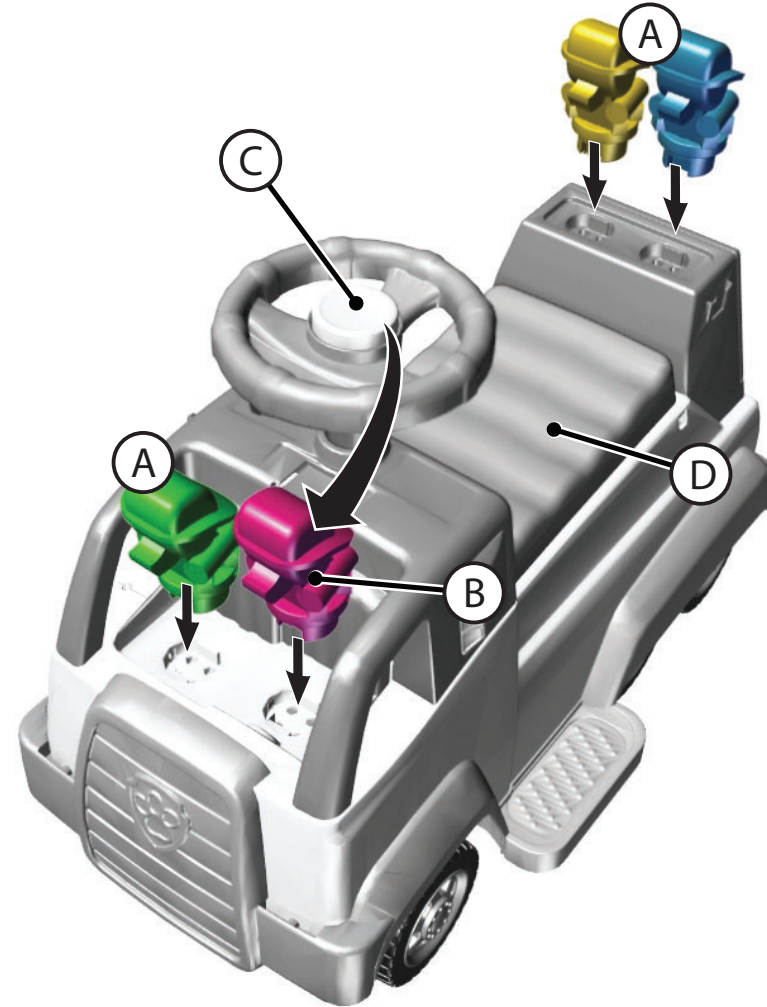

HOW-TO:

- All Figures (A) (B) are interchangeable.
- Place Figures firmly in any of four positions shown.
- Pressing Button (C) will play specific sounds for each Figure placed in 'driver's seat' (B).
- When no Figure is in 'driver's seat' a generic sound will play when pressing Button (C).
- Figures can be stored in Seat Storage Compartment (D).