

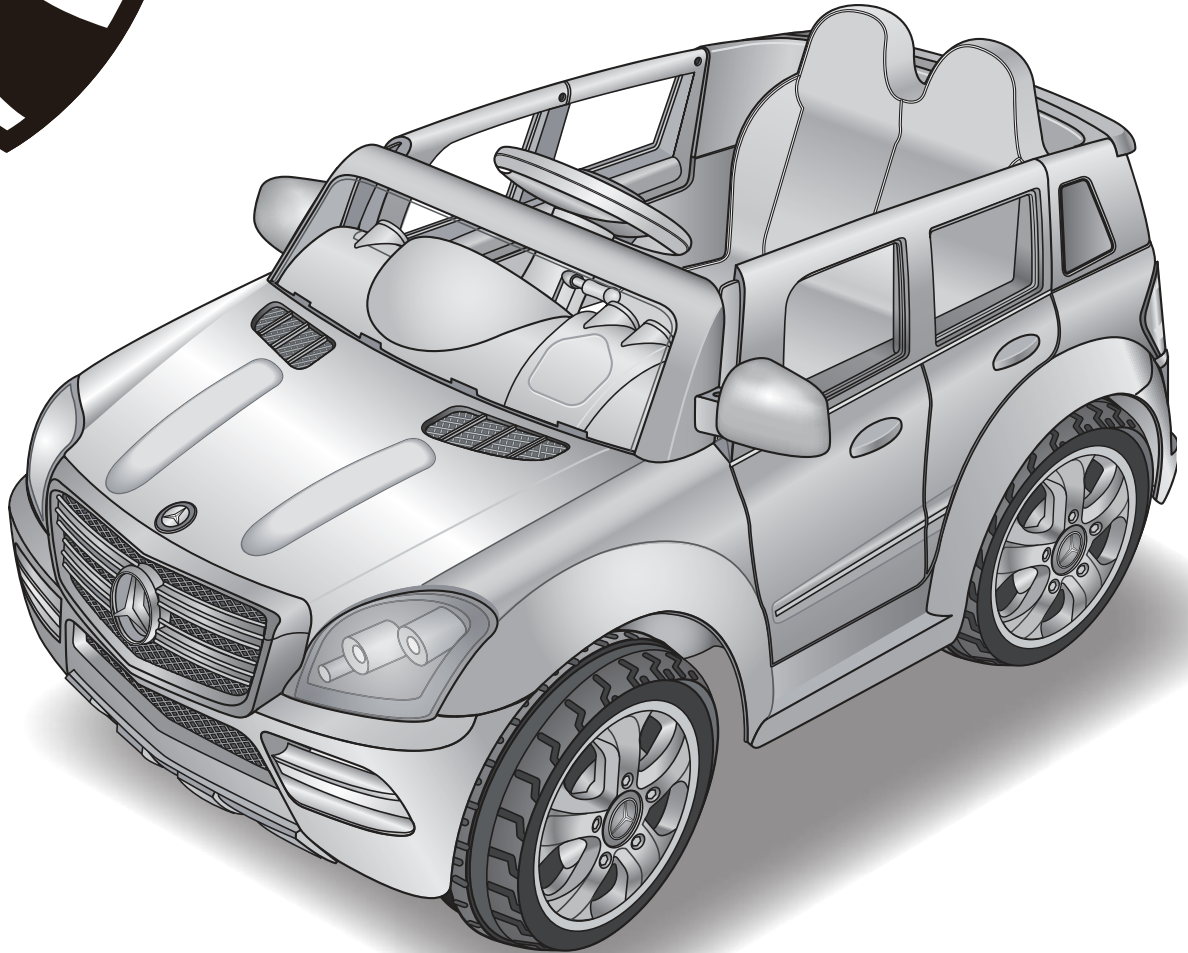

# Mercedes-Benz GL Class



## Operator's Manual

**Before using for the first time the battery needs to be charged for a full 24 hours (no more than 30 hours)**

**Model W488AD 7518**

Styles and colors may vary.  
Made in China.

The owner's manual contains important safety information as well as assembly, use and maintenance instructions. The Mercedes-Benz Ride-on Car must be assembled by an adult who has read and understands the instructions in this manual. Keep the packaging away from children and dispose of properly before use.

**Keep this manual for future reference.**

# Introduction

Thank you for purchasing this vehicle from Hunter. We hope the rider enjoys it for miles to come. Please read this instruction guide carefully before assembling and operating the vehicle. Please have your model number and serial number ready before calling. Please have proof of purchase.

Please contact Hunter Products Customer Service with any questions.

Hours: 9.00 AM - 5.00 PM (AEST), Monday - Friday

Web: [www.electricrideon.com.au](http://www.electricrideon.com.au)

Service Phone: 1800 224 094

## Specifications:

|                  |                 |
|------------------|-----------------|
| BATTERY          | 12V 7AH         |
| MOTOR            | 12V             |
| AGE              | 3 Years and Up  |
| MAX WEIGHT       | 77 lbs. (35 kg) |
| PRODUCT SIZE     | 1125X750X605 mm |
| SPEED            | 2.5 MPH         |
| RECHARGE TIME    | 8-12 Hours      |
| TYPICAL RUN TIME | 1-2 Hours       |
| CHARGER OUTPUT   | 14.8 V          |

# IMPORTANT!

## YOU MUST CHARGE THE BATTERY FOR 24 HOURS BEFORE FIRST USE!

Charge the battery after each use.

Charge the battery at least once a month, even if the vehicle is not in use.

Email or call Customer Service if you need assistance or replacement parts.



**QUESTIONS AND SERVICE**  
**PLEASE CALL: 1800 224 094**  
**email:enquiries@hunterproducts.com.au**

**Read this entire manual to ensure  
proper assembly and safe operation  
of the vehicle.**

# 4 Table of Contents

|                                             |       |
|---------------------------------------------|-------|
| <b>Safety</b> .....                         | 5     |
| <b>User Requirements</b> .....              | 6     |
| <b>Charging the Battery: Warnings</b> ..... | 7     |
| <b>Parts</b> .....                          | 9     |
| <b>Charging Instructions</b> .....          | 10    |
| <b>Assemble the Front Wheels</b> .....      | 11    |
| <b>Assemble the Left Rear Wheel</b> .....   | 12    |
| <b>Assemble the Right Rear Wheel</b> .....  | 13    |
| <b>Attach the Steering Wheel</b> .....      | 14    |
| <b>Attach the Mirrors</b> .....             | 15    |
| <b>Attach the Seat</b> .....                | 16    |
| <b>Battery Removal</b> .....                | 17    |
| <b>Operating Instructions</b> .....         | 18    |
| <b>Maintenance</b> .....                    | 19    |
| <b>General Care</b> .....                   | 20    |
| <b>Troubleshooting Guide</b> .....          | 21-22 |
| <b>Service and Repairs</b> .....            | 23    |
| <b>Warranty</b> .....                       | 24    |
| <b>Product Registration</b> .....           | 26    |



## WARNING!

The following safety hazards may result in serious injury or death to the user of the vehicle Mercedes Ride-on:

- This product contains small parts that are for adult assembly only. Keep small children away when assembling. Remove and dispose of all protective material and poly bags before assembly. Be sure to remove all packaging materials and parts from underneath the car body.
- Riding the vehicle without a helmet. Riders must always wear a fitted helmet that complies with Australian Standard AS/NZS 2063:2008.
- Battery posts, terminals and related accessories contain lead and lead compounds (acid) chemicals that are toxic and corrosive. Never open the battery.
- Body parts such as hands, legs, hair and clothing can get caught in moving parts. Never place a body part near a moving part or wear loose clothing while using the vehicle. Always wear shoes when using the vehicle.
- Using the vehicle near streets, motor vehicles, drop-offs such as: steps, water (swimming pools) or other bodies of water, sloped surfaces, hills, wet areas, flammable vapors, in alleys, at night or in the dark could result in an unexpected accident.
- Always use the vehicle in a safe, secure environment with continuous adult supervision. Never leave the child unattended.
- Using the vehicle in unsafe conditions such as snow, rain, loose dirt, mud, sand or fine gravel may result in unexpected action such as tip over and skidding.
- Using the vehicle in an unsafe manner. Examples include but are not limited to:
  - Pulling the vehicle with another vehicle or similar device
  - Allowing more than one rider
  - Pushing the user from the back
  - Traveling at an unsafe speed
- Always use common sense and safe practices when using the vehicle. Different type of batteries or new and old batteries are not to be mixed.
- Not to be used in traffic.
- This toy is unsuitable for children under 3 years due to its maximum speed.
- Battery charger, electric wire plug enclosure and other parts should be periodically check for damage, if have damage, need to repair before use.

# 6 User Requirements

|                     |                            |
|---------------------|----------------------------|
| <b>Age Range</b>    | 3 to 7 years               |
| <b>Weight Range</b> | No more than 77 lbs (35kg) |

Before using the vehicle the child should understand the vehicle controls and safety issues. They must also demonstrate the capability to handle the vehicle and operate its controls. It is the responsibility of the adult to educate the child and supervise the vehicles use.

Read the following safety warnings to any child using the vehicle Ride-on:

## **WARNING!**

### **PREVENT INJURIES AND DEATHS:**

- **NEVER LEAVE CHILD UNATTENDED. ALWAYS** keep child in view when child is in vehicle. Direct adult supervision is **REQUIRED**.
- **NEVER** use in roadways, near cars, on or near steep inclines or steps, swimming pools or other bodies of water.
- **ALWAYS** wear shoes.
- **ALWAYS** sit on the seat.
- **RISK OF FIRE.** Do not bypass.
- **NEVER** allow more than one (1) rider in the vehicle Ride on.
- Adult assembly required.
- Only use the vehicle when an adult is present to watch (supervise).
- Always sit in the seat when using the vehicle.
- Keep your hands, hair and clothes away from moving parts.
- Always wear shoes when using the vehicle.
- Only one rider is allowed at a time on the vehicle Ride-on.
- Children under three years old cannot use the vehicle.
- Only drive on level ground.
- Do not go near water, drop-offs or up and down steep slopes.
- Do not drive the vehicle into loose dirt, mud, and or fine gravel.
- Do not drive the vehicle on streets or near cars.
- The transformer is not a toy.
- Toys liable to be cleaned with liquids are to be disconnected from the transformer before cleaning.

## **WARNING!**

The following safety hazards may result in serious injury or death to the user of the vehicle:

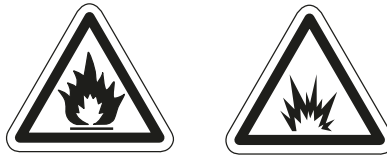

- Use of a battery or charger other than the supplied 12v rechargeable battery and charger may cause a fire or explosion. Only use the supplied 12v rechargeable battery and charger with the vehicle.
- Using the 12v rechargeable battery and charger for any other product may result in over heating, fire or explosion. Never use the 12v rechargeable battery and charger with another product.
- Explosive gases are created during charging. Charge the battery in a well ventilated area. Do not charge the battery near heat or flammable materials.
- Contact between the positive and negative terminals may result in fire or explosion. vehicle direct contact between the terminals. Picking up the battery by the wires or charger can cause damage to the battery and may result in a fire. Always pick up the battery by it's case or handles.
- Liquids on the battery may cause fire or electric shock. Always keep all liquids away from the battery and keep the battery dry.



- Contact or exposure to battery leakage (lead acid) may cause serious injury. If contact or exposure occurs immediately call your physician. If the chemical is on the skin or in the eyes, flush with cool water for 15 minutes. If the chemical was swallowed, immediately give the person water or milk. Do not give water or milk if the patient is vomiting or has a decreased level of alertness. Do not induce vomiting.

## 8 Charging the Battery: Warnings



### WARNING!

- Battery posts, terminals and related accessories contain lead and lead compounds (acid), chemicals and are toxic and corrosive. Never open the battery.



- Tampering or modifying the electric circuit system may cause a shock, fire or explosion and permanently damage to the system. Exposed wiring, circuitry in the charger may cause electric shock. Always keep the charger housing closed.

**Important!** Before using the vehicle for the time the battery needs to be charged for a full twenty-four hours (no more than thirty hours). Only an adult who has read and understands the following safety warnings should handle, charge or recharge of the battery (see Maintenance).

**Note:** It is not necessary to remove the battery from the vehicle for charging. However, if the adapter cord will not safely reach a 240V wall outlet, the battery can be removed for charging (see page 10 for instructions concerning battery replacement).



### WARNING!

- Non-rechargeable batteries are not to be recharged;
- Batteries are to be inserted with the correct polarity;
- Exhausted batteries are to be removed from the toy;
- The supply terminals are not to be short-circuited.
- Rechargeable batteries are only to be charged under adult supervision;
- Rechargeable batteries are to be removed from the toy before being charged;



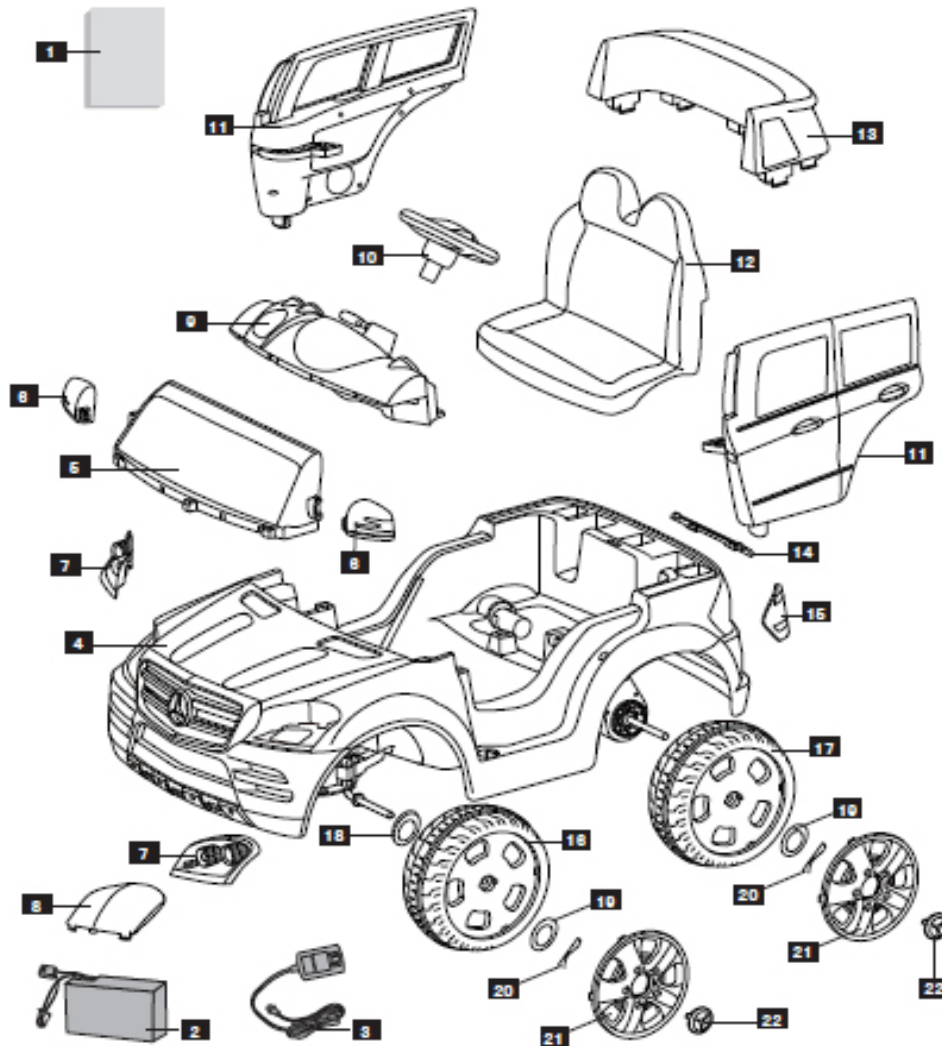

- |                       |                      |
|-----------------------|----------------------|
| 1. Manual             | 11. Door             |
| 2. Battery            | 12. Seat             |
| 3. Battery Charger    | 13. Back Empennage*  |
| 4. Car Body           | 14. Rear Decoration* |
| 5. Windshield*        | 15. Tail Light*      |
| 6. Mirrors (2)        | 16. Front Wheel      |
| 7. Front Light*       | 17. Rear Wheel       |
| 8. Front Light Cover* | 18. Thick Washer     |
| 9. Dashboard*         | 19. Flat Washer      |
| 10. Steering Wheel    | 20. Snap Pins (4)    |
|                       | 21. Rim              |
|                       | 22. Hub Cap          |

Not Included:

- Phillips screwdriver
- Pliers
- 2 AAA Batteries

\*Parts denoted with an asterik are pre-assembled on the vehicle

# 10 Charging Instructions

## YOU MUST CHARGE THE BATTERY FOR 24 HOURS BEFORE THE FIRST USE!

**ONLY AN ADULT SHOULD HANDLE THE BATTERY AND CHARGER.**

### To Charge the Battery:

1. Ensure the car is stopped and turned off.
2. Unlock and remove the seat.
3. Unplug the red battery connector (A) from the red engine connector (B).
4. Connect the red battery connector (A) to the red battery charger connector (C) and plug (D) into a 240 V outlet.

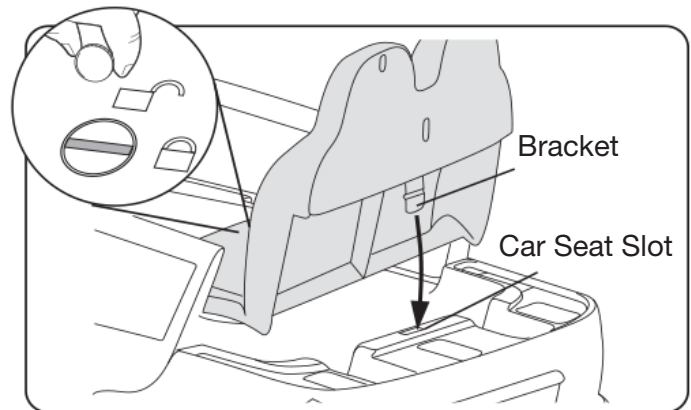

### To Unplug the Battery:

1. Unplug the battery charger (D) from the outlet.
2. Unplug the red battery connector (A) from the red engine connector (B).
3. Reconnect the red battery connector (A) to the red engine connector (B).
4. Replace the seat and tighten lock.

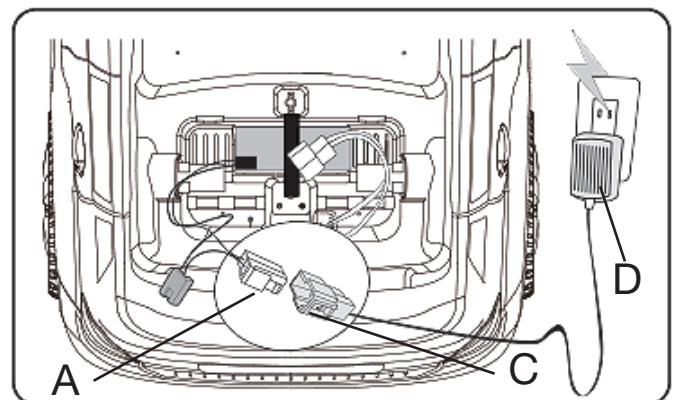
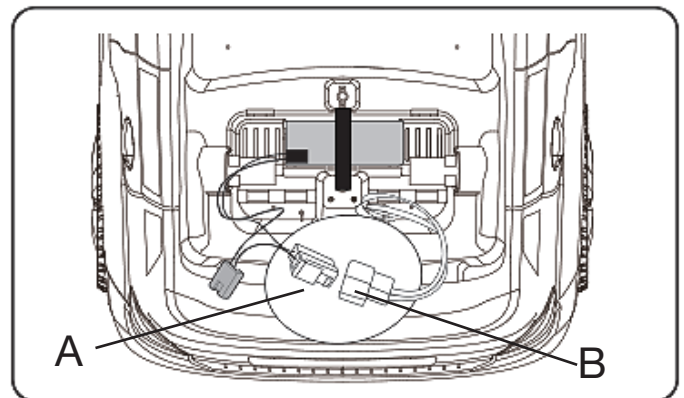

Note: It is not necessary to remove the battery for charging. However, if the battery does not reach the outlet, it can be removed for charging. For Battery Removal instructions, see Page 16.

# Assemble the Front Wheels 11

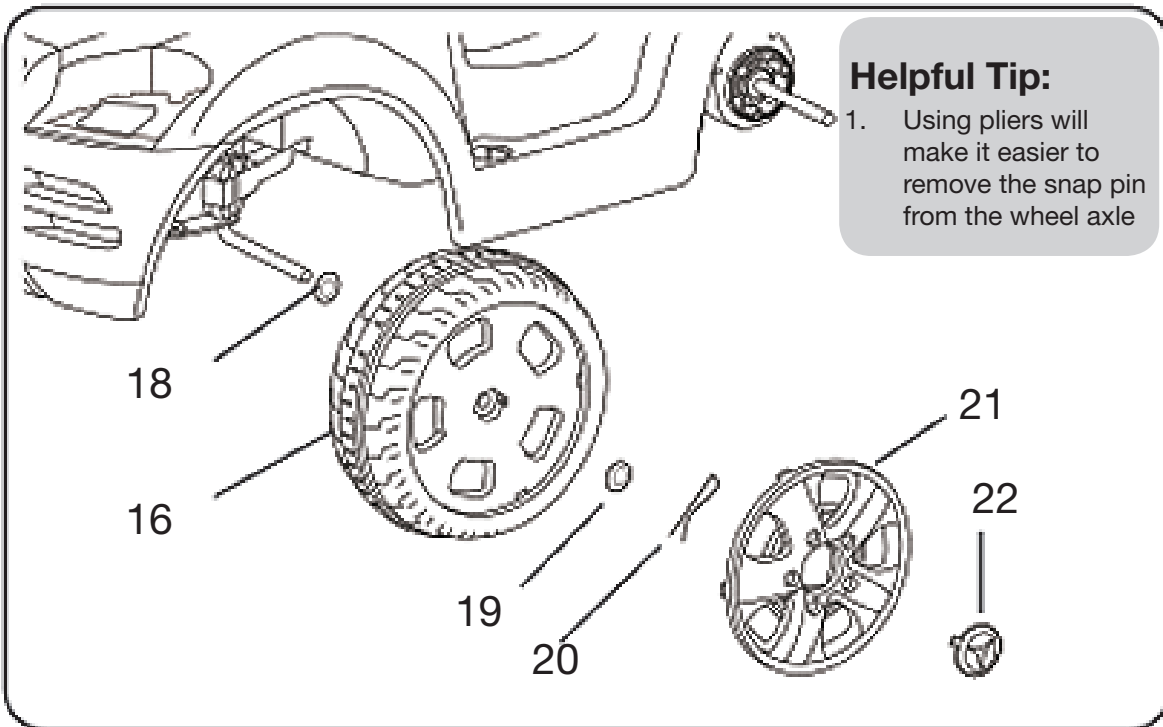

1. Slide the front thick washer (18) onto the front axle.
2. Slide the front wheel (16) onto the front axle.
3. Slide the front flat washer (19) onto the front axle.
4. Slide the snap pin (20) into the hole on the front axle until firmly attached. Tip: Pliers may be helpful when removing the snap pin.
5. Snap the rim (21) onto the wheel.
6. Snap the hub cap (22) onto the completed wheel assembly.
7. Repeat steps 1-6 for the remaining front wheel.

## 12 Assemble the Left Rear Wheel

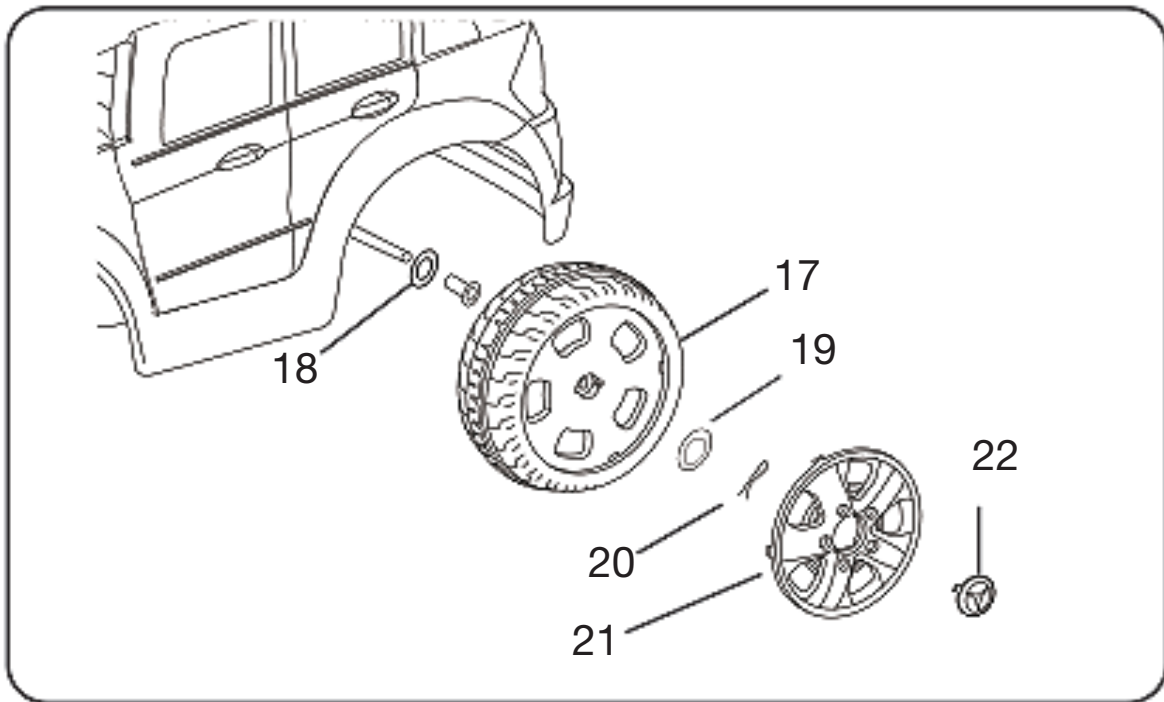

### **Left Rear Wheel:**

1. Slide the rear thick washer (18) onto the left rear axle.
2. Slide the orientation sleeve onto the left rear wheel axle.
3. Slide the left rear wheel (17) onto the left rear axle. The side with the gear teeth faces inward.
4. Slide the rear flat washer (19) onto the left rear axle.
5. Slide the snap pin (20) into the hole on the left rear axle until firmly attached.
6. Snap the rim (21) onto the left wheel assembly.
7. Snap the hub cap (22) onto the completed left wheel assembly.

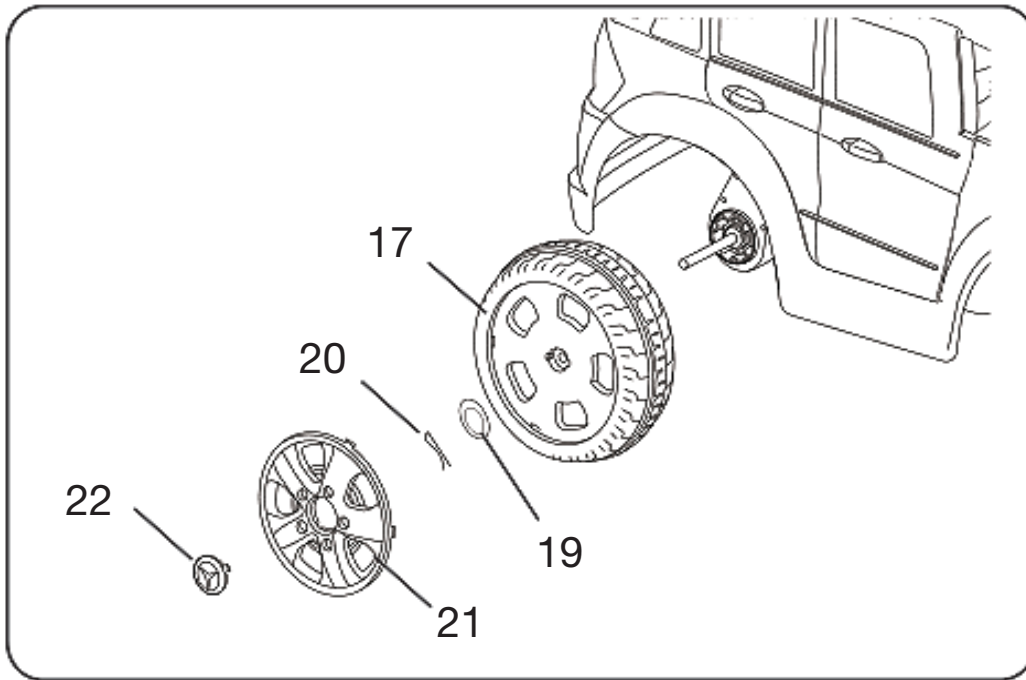

## Right Rear Wheel:

1. Slide the right rear wheel (17) onto right rear wheel axle. The side with gear teeth faces inward. (Note: the gear teeth must engage with the gear box.)
2. Slide the rear flat washer (19) onto the right rear axle.
3. Slide the snap pin (20) into the hole on the right rear axle until firmly attached.
4. Snap the rim (21) onto the right wheel.
5. Snap the hub cap (22) onto the completed wheel assembly.

## Helpful Tip:

1. If you encounter trouble fitting both wheels onto the rear axle, then your rear wheel axle may need to be realigned.
2. Remove both wheels from the rear wheel axle. Using two hands, push down on the rear wheel axle and slide it gently toward the side of the vehicle that needs more room.
3. Once the rear axle is properly centered, refer to the above steps to assemble the wheels.

## 14 Attach the Steering Wheel

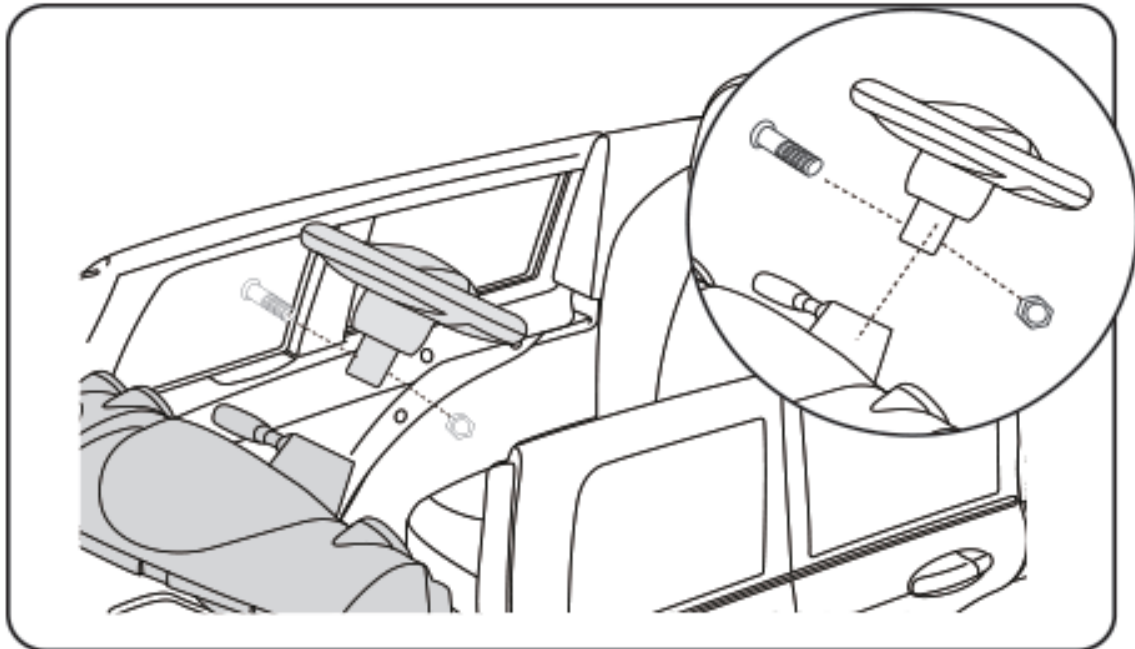

1. Remove the screw and nut from the steering wheel assembly before attaching
2. Insert the steering wheel (10) into the steering rod, and match the screw holes of the steering wheel with the screw holes on the steering rod
3. Insert the screw into the hole and fasten the nut to secure

Steering wheel requires 2 x 1.5V AAA batteries

1. Open the battery compartment cover with the screwdriver
2. Insert the two batteries into the battery compartment
3. Replace the battery compartment cover and securely close with the screw

Note:

If steering wheel sounds become distorted or slow, please change the batteries based on the above procedure.

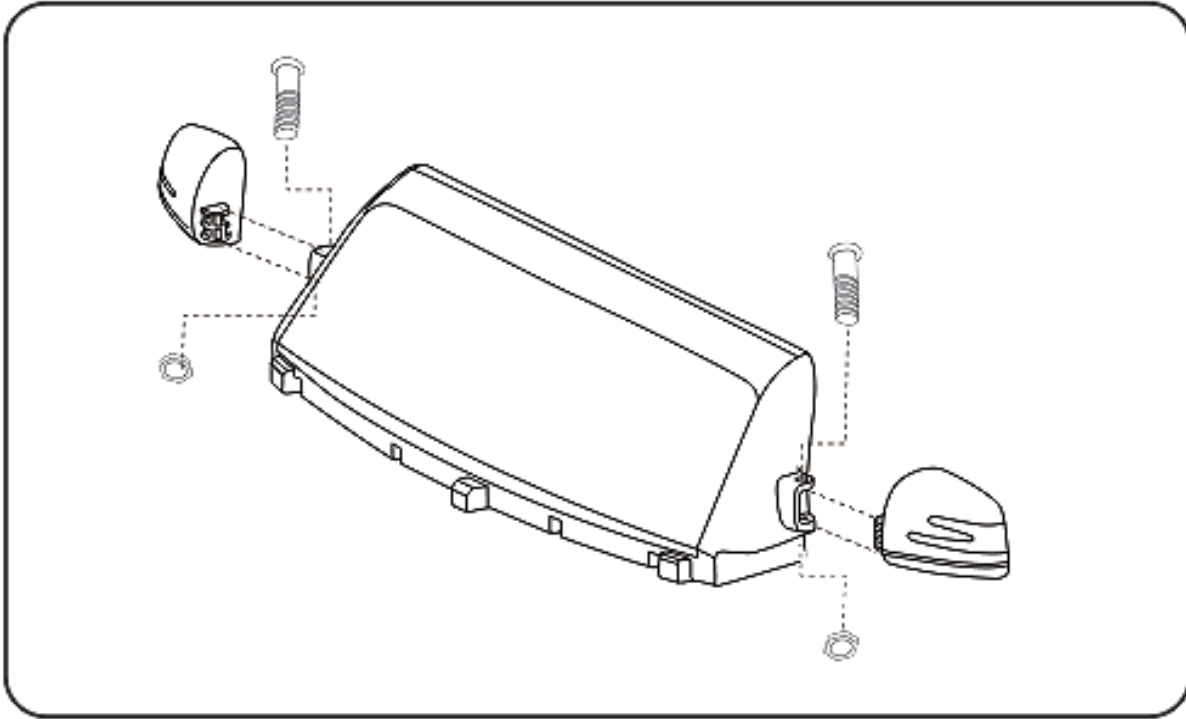

1. Align the holes of the left side mirror (6) with the hole on the mirror hinge.
2. Insert the screw through the mirror and mirror hinge holes. Screws come installed on the mirrors.
3. Screw a small nut to the bottom of the screw, don't over tighten.
4. Repeat steps 1-3 for the right side mirror.

## 16 Attach the Seat

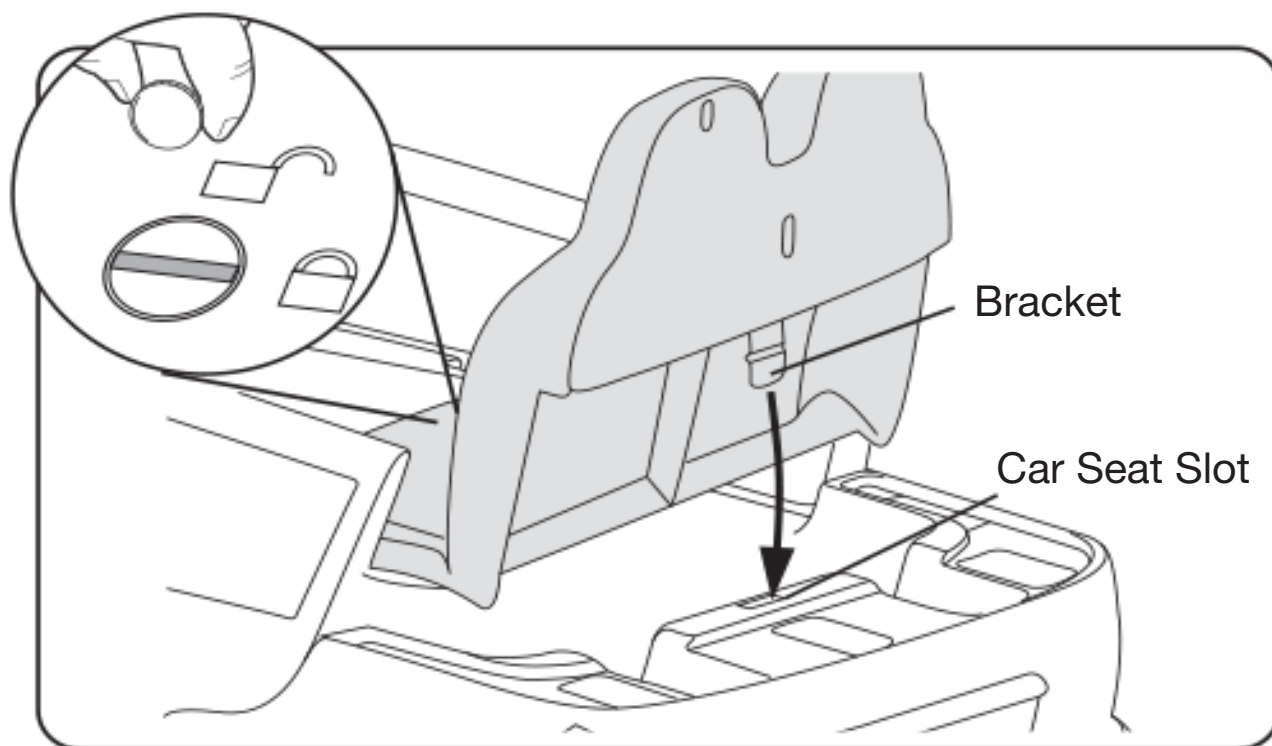

1. Locate the bracket behind the back of the car seat (12)
2. Align the car seat bracket with the car seat slot and the T-Lock with the car seat lock hole. Lower the seat into place.
3. Lock the car seat in place by using a coin to tighten the T-Lock located in the center of the car seat bottom.
4. To remove the seat, turn the T-Lock to unlock position and pull the seat upward.



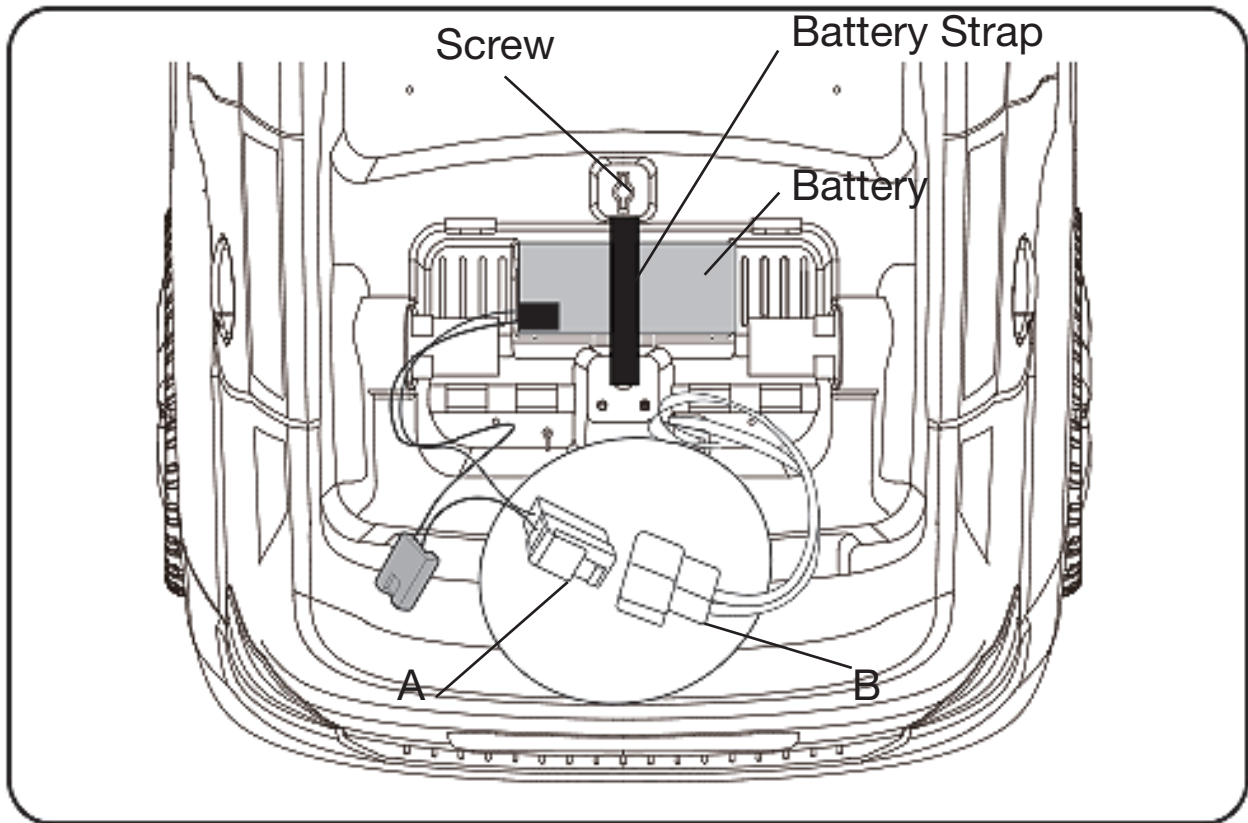

1. Disconnect the red battery connector (A) from the red engine connector (B)
2. Loosen and remove the screw
3. Unfasten the battery from the strap
4. Remove the battery.

Note: It is not necessary to remove the battery for charging. However, if the battery does not reach the outlet, it can be removed for charging.

# 18 Operating Instructions

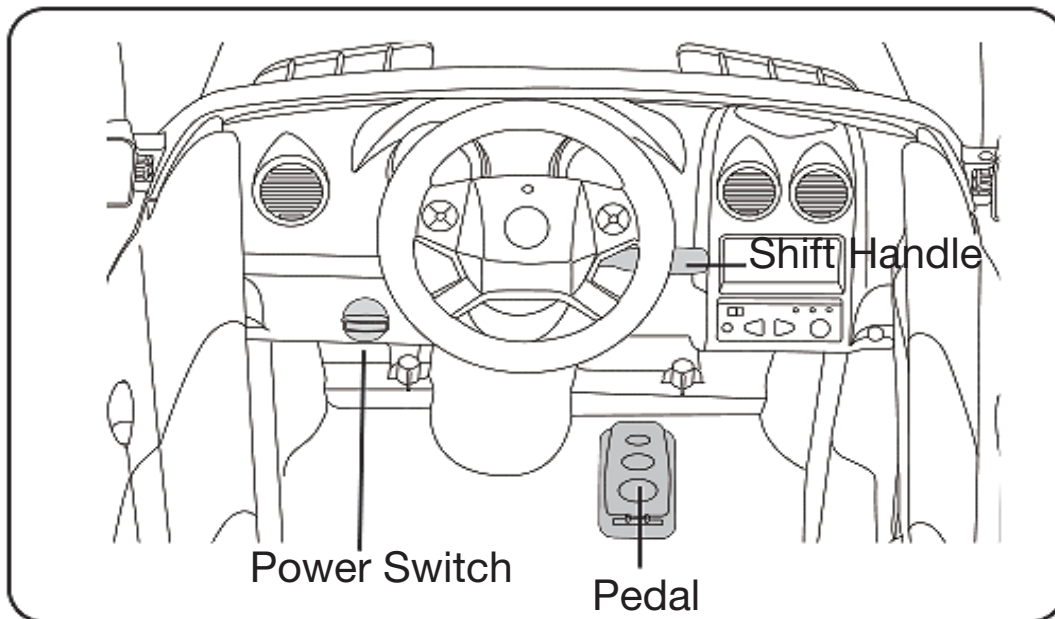

- To turn on the vehicle, turn the power switch to “On”
- Push the shifter upward to move forward. Pull the shifter downward to go in reverse
- Press the foot pedal down to go. Release the foot pedal to stop

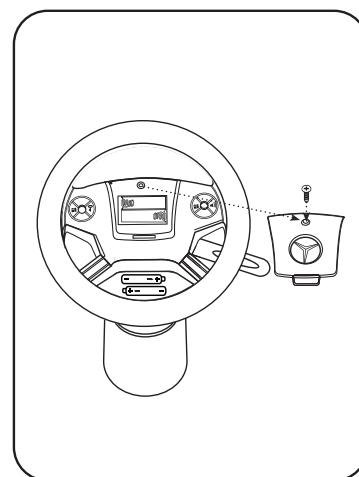
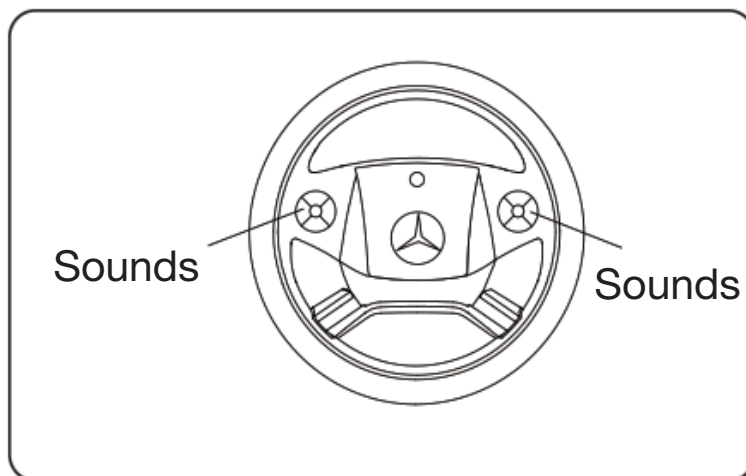

- Press the left and right buttons on the steering wheel to make sounds.
- Note: The steering wheel requires 2 x 1.5V AAA batteries to make sounds.

## **⚠ WARNING!**

- DO NOT mix old and new batteries.
- DO NOT mix alkaline, standard (carbon-zinc), or rechargeable (nickel-cadmium) batteries.

## Important Battery and Charger Information

- Only an adult who has read and understands the safety warnings may handle and operate the battery and battery charger. Keep away from children.
- Charge the battery for 24 hours before using the vehicle for the first time.
- Charge the battery immediately after each use. Charge for at least 8-12 hours, but no more than 20 hours.
- Charge the battery at least once a month, even if the vehicle is not used or stored.
- Never leave the battery in a discharged condition.
- Connect the terminal of the battery and charger, then plug the charger into a 240V AC outlet.
- It is normal for the charger to heat slightly. If the charger rises above 71°C / 160°F, disconnect the charger and call Customer Service for assistance.
- Keep the charger away from water or excessive moisture to prevent short-circuiting.
- Only use the charger specified with the original item. **Do not charge the battery with any other charger.**
- Do not attempt to recharge non-rechargeable batteries with the original charger.
- **Do not replace the battery with any other battery, or the warranty will be voided.** If you need a replacement battery, see Page 24 for replacement information.
- Remove damaged batteries from the car immediately. Recycle or dispose of the used batteries responsibly.
- Do not short circuit the supply terminals.
- Do not leave the battery connected in the vehicle for extended periods of time when the vehicle is not being used. Disconnect the battery connector from the engine connector before storing.
- The vehicle is equipped with a thermal fuse to protect the electric circuit. If the vehicle cuts out, turn the vehicle off and on to reset.

## 20 General Care

- Regularly inspect all vehicle parts to ensure they are in good working condition.
- Regularly inspect the charger, cord, plug, and other related parts for damage.
- Remove any damaged parts and immediately contact Customer Service for replacement parts. See Service and Repairs on Page 24 for more information.
- DO NOT operate the vehicle if there are any damaged parts.
- Carefully clean the vehicle with a damp cloth and mild soap. Do not get water in or near any electrical parts. Do not wash the vehicle with a hose.
- Store the vehicle indoors or use a tarp to cover it. Keep away from stoves, heaters, or other sources of heat.

Completely read through the manual and troubleshooting guide before contacting Customer Service.

| Problem                            | Potential Cause                 | Solution                                                                                                      |
|------------------------------------|---------------------------------|---------------------------------------------------------------------------------------------------------------|
| Vehicle does not run               | Battery is low                  | Recharge the battery                                                                                          |
|                                    | Thermal fuse tripped            | Reset fuse                                                                                                    |
|                                    | Snap pins are loose             | Tighten snap pins                                                                                             |
|                                    | Loose wires or loose connectors | Ensure the battery connectors are securely attached. If wires are loose, contact Consumer Service for repairs |
|                                    | Battery is dead                 | Call Customer Service for replacement battery                                                                 |
|                                    | Electrical system is damaged    | Call Customer Service for repairs                                                                             |
|                                    | Motor is damaged                | Call Customer Service for repairs                                                                             |
| Vehicle only runs for a short time | Undercharged battery            | Ensure a secure connection when the battery is recharging. Recharge for at least 8-12 hours                   |
|                                    | Overcharged battery             | Never charge the battery for more than 24 hours                                                               |
|                                    | Battery is old                  | Replace battery                                                                                               |
| Vehicle runs slowly                | Battery is not fully charged    | Ensure a secure connection when the battery is recharging                                                     |
|                                    | Battery is old                  | Call Customer Service to order replacement battery                                                            |
|                                    | Too much weight on vehicle      | Reduce weight on vehicle (77 lbs max)                                                                         |
|                                    | Harsh conditions                | Operate the vehicle on level ground and safe surfaces                                                         |

| Problem                                       | Potential Cause                             | Solution                                                                                                      |
|-----------------------------------------------|---------------------------------------------|---------------------------------------------------------------------------------------------------------------|
| Vehicle needs a push to start                 | Loose wires or loose connectors             | Ensure the battery connectors are securely attached. If wires are loose, contact Consumer Service for repairs |
|                                               | “Dead spot” on motor                        | A “dead spot” means electricity is not being delivered to the terminal. Contact Consumer Service for repairs  |
| Difficulty shifting                           | Attempting to shift while vehicle is moving | Stop the vehicle before shifting                                                                              |
| Motor or gear box making grinding noises      | Motor or gear damage                        | Contact Consumer Service for repairs                                                                          |
| Battery will not recharge                     | Charger is not plugged in                   | Plug in the charger to a functional wall outlet                                                               |
|                                               | Charger is not working                      | Call Consumer Service for a replacement                                                                       |
|                                               | Loose connector or loose adapter            | Check that the connectors are securely plugged in to each other                                               |
| Battery makes bubbling noise while recharging | This is normal                              | No action required                                                                                            |
| Charger is warm                               | This is normal                              | No action required                                                                                            |

If your product requires service, repairs or replacement parts, please visit us online at [www.electricrideon.com.au](http://www.electricrideon.com.au)

Or contact us at:

Toll Free Service Phone: 1800 224 094

email: [www.enquiries@hunterproducts.com.au](mailto:www.enquiries@hunterproducts.com.au)

Hours: 9.00 AM - 5.00 PM (AEST), Monday - Friday

## One-Year Limited Warranty

Hunter Products warrants that your **vehicle 12v** will be free from defects in materials and workmanship for the vehicle (except for the 6-volt battery) for a period of 12 months, from the date of purchase. This warranty only applies where the product is completely and correctly assembled and used in accordance with all accompanying recommendations and users instructions. This warranty is in addition to your rights under the Australia Consumer Law.

Hunter Products, at its option will provide you with a refund or replacement parts for this product if the **vehicle 12v** becomes defective within the warranty period. Hunter Products will bear the reasonable expense of claiming the warranty. This warranty will no longer apply where the defect is a result of an accident, misuse, abuse, neglect or other causes not arising out of defects in materials or workmanship, nor does it cover damages arising out of damages arising out of service by other than an authorised service person.

Our goods come with guarantees that cannot be excluded under the Australian Consumer Law. You are entitled to a replacement or refund for a major failure and compensation for any other reasonably foreseeable loss or damage. You are also entitled to have the goods repaired or replaced if the goods fail to be of acceptable quality and the failure does not amount to a major failure.

Please retain your receipt as proof of purchase and contact Hunter Products for further assistance on how to process any warranty claims.

**Business name:** Hunter Products Pty Ltd  
**Business address:** Level 2, 424 Warrigal Road, Moorabbin VIC 3189, Australia  
**Toll Free Phone:** 1800 224 094 (Monday to Friday 9.00 to 5.00pm AEST)  
**Email address:** [enquiries@hunterproducts.com.au](mailto:enquiries@hunterproducts.com.au)





# 26 Product Registration

Fill out the form below and mail it to:

Hunter Products Pty Ltd  
Level 2, 424 Warrigal Road,  
Moorabbin VIC 3189,  
Australia

OR email to [enquiries@hunterproducts.com.au](mailto:enquiries@hunterproducts.com.au)

We will use the information provided only for your warranty. We will not sell, rent or share your personal information.

---

## Product Registration

First Name: \_\_\_\_\_ Last Name: \_\_\_\_\_ Title: \_\_\_\_\_

Address: \_\_\_\_\_

City: \_\_\_\_\_ State: \_\_\_\_\_ Zip Code: \_\_\_\_\_

Email: \_\_\_\_\_ Phone: \_\_\_\_\_

Date of Purchase: \_\_\_\_\_

**The following product information is on the cover of the owner's manual.**

Product Name: \_\_\_\_\_ Model Number: \_\_\_\_\_

Serial Number: \_\_\_\_\_